



## REQUEST FOR PROPOSAL (RFP)

FOR

Supply, Installation & Maintenance of Optical Line  
Amplifiers for AP Fiber Grid

Ref. No. APSFL/OLA/284-1/2018, Dated 02/03/2019

Andhra Pradesh State FiberNet Limited

NTR Administrative Block, 3rd Floor, Pandit Nehru Bus Station,

Vijayawada - 520013

Web address: [www.apsfl.in](http://www.apsfl.in)

Email address: [apsfl@ap.gov.in](mailto:apsfl@ap.gov.in)

# Table of Contents

<b>Disclaimer</b>	<b>4</b>
<b>Acronyms</b>	<b>5</b>
<b>Definitions</b>	<b>6</b>
<b>1. Inviting Authority</b>	<b>7</b>
1.1 Key Events and Dates	7
1.2 Procedure for Bid Submission	8
1.3 Hard Copies	8
<b>2. Introduction</b>	<b>9</b>
<b>3. Scope of Work</b>	<b>11</b>
3.1 Delivery & Commissioning Phase	11
3.2 User Acceptance Test	12
3.3 Maintenance Phase	12
<b>4. Pre-Qualification Criteria</b>	<b>14</b>
<b>5. Schedule of Requirement</b>	<b>16</b>
<b>6. Technical Bid Evaluation</b>	<b>17</b>
<b>7. Instructions to the Bidder</b>	<b>18</b>
7.1 General	18
7.2 Pre-bid Queries	18
7.3 Language of the Bid	18
7.4 Amendments	19
7.5 Clarifications by APSFL	19
7.6 Suppression of facts and misleading information	19
7.7 Contacting Tender Inviting Authority	19
7.8 Tender Validity	20
7.9 Hand written documents, Erasures or Alterations	20
7.10 Bid Prices	20
7.11 Letter of Authorization	20
7.12 Conditional Bids/Offer by the Bidders	20
7.13 Late Tender Bids	20
7.14 Opening of Bids	21
7.15 Right to Accept or Reject Bids	21
7.16 Notification of Award	21
7.17 Earnest Money Deposit	21
7.18 Performance Bank Guarantee	21
7.19 Signing of Agreement	22
7.20 Rejection Criteria	22
7.21 Concessions permissible under statutes	22
7.22 Bid forms	23
7.23 Delivery Timelines	23
7.24 Delivery & Documents	23
7.25 Third Party Claims	23
7.26 Inspection & Test	23

7.27	Execution of Work Order .....	23
7.28	Service Levels & Warranty .....	24
7.29	Payment Terms & Time Lines.....	25
7.30	Force Majeure .....	25
7.31	Liquidated Damages .....	25
7.32	Termination of Contract.....	26
7.33	Arbitration and Jurisdiction .....	27
<b>8.</b>	<b>Annexures.....</b>	<b>28</b>
8.1	Checklist.....	28
8.2	Annexure I – Cover Letter .....	29
8.3	Annexure II – Bidder Profile.....	30
8.4	Annexure III - Financial Information.....	30
8.5	Annexure IV- Declaration of Acceptance of RFP Terms & Conditions.....	32
8.6	Annexure V - Declaration of Clean Track Record/ No Blacklisting.....	33
8.7	Annexure VI -EMD Format .....	34
8.8	Annexure VII – Performance Bank Guarantee Format.....	35
8.9	Annexure VIII- Manufacturer’s Authorization Form (MAF).....	36
8.10	Annexure IX – Price Bid Form .....	37
8.11	Annexure X – Minimum Tech Specifications.....	39

## Disclaimer

The information contained in this Request for Proposal document (“RFP”) or subsequently provided to Applicants, whether verbally or in documentary or any other form by or on behalf of the APSFL or any of its employees or advisers, is provided to Applicants on the terms and conditions set out in this RFP and such other terms and conditions subject to which such information is provided.

This RFP is not an agreement and is neither an offer nor invitation by the APSFL to the prospective Applicants or any other person. The purpose of this RFP is to provide interested parties with information that may be useful to them in the preparation of their Proposals pursuant to this RFP. This RFP includes statements, which reflect various assumptions and assessments arrived at by APSFL. Such assumptions, assessments and statements do not purport to contain all the information that each Applicant may require. This RFP may not be appropriate for all persons, and it is not possible for APSFL, its employees or advisers to consider the objectives, technical expertise and particular needs of each party who reads or uses this RFP. The assumptions, assessments, statements and information contained in this RFP, may not be complete, accurate, adequate or correct. Each Applicant should, therefore, conduct its own investigations and analysis and should check the accuracy, adequacy, correctness, reliability and completeness of the assumptions, assessments and information contained in this RFP and obtain independent advice from appropriate sources.

Information provided in this RFP to the Applicants is on a wide range of matters, some of which depends upon interpretation of law. The information given is not an exhaustive account of statutory requirements and should not be regarded as a complete or authoritative statement of law. APSFL accepts no responsibility for the accuracy or otherwise for any interpretation of the law.

APSFL, its employees and advisers make no representation or warranty and shall have no liability to any person including any Applicant under any law, statute, rules or regulations or tort, principles of restitution or unjust enrichment or otherwise for any loss, damages, cost or expense which may arise from or be incurred or suffered on account of anything contained in this RFP or otherwise, including the accuracy, adequacy, correctness, reliability or completeness of the RFP and any assessment, assumption, statement or information contained therein or deemed to form part of this RFP or arising in any way in this Selection Process.

APSFL also accepts no liability of any nature whether resulting from negligence or otherwise, howsoever caused, arising from reliance of any Applicant upon the statements contained in this RFP. APSFL may in its absolute discretion, but without being under any obligation to do so, update, amend or supplement the information, assessment or assumption contained in this RFP.

Issuance of this RFP does not imply that the APSFL is bound to select an Applicant or to appoint the Selected Applicant, as the case may be, for the RFP, APSFL reserves the right to reject all or any of the Proposals without assigning any reasons whatsoever.

The applicant shall bear all its costs associated with or relating to the preparation and submission of its Proposal including but not limited to preparation, copying, postage, delivery fees, expenses associated with any demonstrations which may be required by the APSFL or any other costs incurred in connection with or relating to its Proposal. All such costs and expenses will remain with the Applicant and APSFL shall not be liable in any manner whatsoever for the same or for any other costs or other expenses incurred by an Applicant in preparation or submission of the Proposal, regardless of the conduct or outcome of the selection process

## Acronyms

APSFL	Andhra Pradesh State FiberNet Limited
BG	Bank Guarantee
DD	Demand Draft
EMD	Earnest Money Deposit
GST	Goods and Services Tax
INR	Indian National Rupee
ISP	Internet Service Provider
LD	Liquidated Damages
LLP	Limited Liability Partnership
LoA	Letter of Acceptance
MTTR	Mean Time To Repair/Replace
NOC	Network Operations Centre
OEM	Original Equipment Manufacturer
PBG	Performance Bank Guarantee
PoP	Point of Presence
PSU	Public Sector Unit
SD	Security Deposit
SLA	Service Level Agreement
SOP	Standard Operating Procedure
SPOC	Single Point of Contact
GST	Goods and Services Tax

## Definitions

- **“Agreement”** means the Agreement to be signed between the successful bidder and APSFL including all attachments, appendices, all documents incorporated by reference thereto together with any subsequent modifications, the RFP, the bid offer, the acceptance and all related correspondences, clarifications, presentations.
- **“Authority”** refers to MD/Directors of APSFL or its nominated representatives
- **“Authorized Representative”** shall mean any person authorized by either of the parties.
- **“Bidder”** means any firm or group of firms (called consortium) offering the solution(s), service(s) and /or materials as required in the RFP. The word Bidder/ System Integrator when used in the pre-award period shall be synonymous with parties bidding for this RFP, and when used after award of the Contract shall mean the successful party with whom APSFL signs the agreement for rendering of services for implementation of this project.
- **“Contract”** is used synonymously with Agreement.
- **“Go-Live”** is successful commissioning and integration with APSFL Network.
- **“Law”** shall mean any Act, notification, bye law, rules and regulations, directive, ordinance, order or instruction having the force of law enacted or issued by the Central Government and/ or Andhra Pradesh or regulatory authority or political subdivision of government agency.
- **“LoA”** means Letter of Acceptance, which shall constitute the intention of the department to place the Purchase Order with the successful bidder.
- **“Party”** means APSFL or Bidder, individually and “Parties” mean APSFL and Bidder, collectively.
- **“Proposal / Bid”** means the Pre-Qualification and Technical Proposals submitted along with the subsequent clarifications and undertakings, if any;
- **“Request for Proposal (RFP)”** means this document and its annexure etc., seeking a set of solution(s), services(s), materials and/or any combination of them.
- **“Requirements”** shall mean and include schedules, details, description, statement of technical data, performance characteristics and standards (Indian & International) as specified in RFP.
- **“Service Level(s)”** means the performance standards, which shall apply, to the solution design, implementation & services delivered by the Empanelled Agency.
  - **“Service Centre”** The centre or place, wherein the Bidder, inter alia undertakes and performs the service activities relating to tendered items and shall include a direct service centre or authorized dealer or franchisee service centre of the bidder in 13 Districts of Andhra Pradesh.

## 1. Inviting Authority

Andhra Pradesh State FiberNet Limited (APSFL) invites sealed bids from the prospective bidders for supply, Installation and Maintenance of Optical Line Amplifiers for AP Fiber Grid. The bidders shall propose all the components as per the technical specifications mentioned in this RFP and selected bidder(s) should support APSFL in providing reliable service delivery.

### 1.1 Key Events and Dates

Sl. No.	Description	Details
1.	Name of the Authority	Andhra Pradesh State FiberNet Limited
2.	Name of the Assignment	Supply, Installation and Maintenance of Optical Line Amplifiers for AP Fiber Grid
3.	RFP Number	APSFL/OLA/284/2018, Dated 01/03/2019, dated <b>02/03/2019</b>
4.	RFP Publishing Date	<b>02/03/2019</b>
5.	Date and time for receiving queries/clarifications	<b>On or Before 07/03/2019 at 5:00 PM</b> <b>No queries shall be entertained after above timeline.</b>
6.	Last date and time for submission of proposal (Proposal Due Date)	<b>On or Before 15/03/2019 at 3:00 PM</b> The proposal is to be submitted at Andhra Pradesh State FiberNet Limited NTR Administrative Block, 3rd Floor, Pandit Nehru Bus Station, NH -65, Vijayawada - 520013
7.	Date and time of opening of pre-qualification cum technical bids on e-procurement platform	<b>15/03/2019 at 4:00 PM</b> Andhra Pradesh State FiberNet Limited NTR Administrative Block, 3rd Floor, Pandit Nehru Bus Station, NH -65, Vijayawada - 520013 Web address: <a href="http://www.apsfl.in">www.apsfl.in</a> Email address: <a href="mailto:apsfl@ap.gov.in">apsfl@ap.gov.in</a>
8.	Date and time of opening of financial bid	Shall intimate technically qualified agencies at a later date
9.	Bid Processing Fee (Non-refundable)	<b>INR 50,000 (Rupees Fifty Thousand Only)</b> in the form of Demand Draft issued by one of the Nationalized / Scheduled Banks in India drawn in favour of <b>Andhra Pradesh State FiberNet Ltd'</b> , payable at Vijayawada.  Original DD must be submitted in APSFL office at Vijayawada before proposal due date.
10.	Bid Security / EMD (Refundable)	<b>INR 3,00,000 (INR Three Lakh Rupees Only)</b> in the form of <b>Bank Guarantee</b> issued by one of the Nationalized / Scheduled Commercial Banks in India drawn in favour of <b>Andhra Pradesh State FiberNet Ltd</b> , payable at Vijayawada. Original BG must be submitted in APSFL office at Vijayawada before proposal due date.  Bid Security / EMD should be valid for a period of 210 days from Proposal Due Date. The Bid Security / EMD will be refunded to unsuccessful Applicant agencies within 30 (Thirty) days of completion of selection process.
11.	Performance Bank Guarantee	<b>10% of the Contract Value</b> in the form of Bank Guarantee issued by one of the Nationalized / Scheduled Commercial Banks in India drawn in favour of <b>Andhra Pradesh State FiberNet Ltd</b> ,

		payable at Vijayawada. <ul style="list-style-type: none"> <li>▪ Should be valid for contract period + 3 months</li> </ul>
12.	Warranty & Maintenance*	Comprehensive onsite warranty & Maintenance for a period of 5 year for all equipment from the date of go-live.
13.	For any enquiries and clarifications, please contact:	Executive Director –Technical, Andhra Pradesh State FiberNet Limited NTR Administrative Block, 3rd Floor, Pandit Nehru Bus Station, Vijayawada - 520013 Web address: <a href="http://www.apsfl.in">www.apsfl.in</a> Email: <a href="mailto:apsfl@ap.gov.in">apsfl@ap.gov.in</a>
14.	Validity of the Proposal	Bidder proposals shall remain valid for a period of 180 days from the Proposal due date.
15.	Method of Selection	L1

## 1.2 Procedure for Bid Submission

The bidders shall submit their Pre-Qualification cum Technical bid and Price bid in separate sealed envelopes at APSFL Head Office, Vijayawada. The bidders shall submit the scanned copies of all the relevant certificates, documents etc., in support of their Pre-Qualification cum Technical bids and other certificates/documents with clear readability. The bidder should sign on all the statements, documents, certificates.

## 1.3 Hard Copies

All bidders should submit below documents in hard copy Original DD towards the bid processing fee & Original BG towards EMD in APSFL office at Vijayawada before proposal due date.

- i. APSFL shall carry out the evaluation solely based on the submitted certificates/documents, BG towards EMD in the e-Procurement system and open the price bids of the responsive bidders only.
- ii. APSFL will notify the bidders for submission of original hardcopies of the submitted documents if required.
- iii. APSFL will not take any responsibility for any delay in receipt/non-receipt of original DD/BG towards Document Fee/ EMD before the stipulated time.

On receipt of documents, APSFL shall ensure the genuineness of the DD towards document fee, BG towards EMD and all other certificates/documents submitted by the bidder in support of the qualification criteria before concluding the agreement.



## 2. Introduction

Andhra Pradesh State FiberNet Limited (APSFL) has been incorporated under the Companies Act 2013 in October 2015, to undertake the works of AP Fiber Grid, its operations & maintenance and related business activities. It is a fully owned entity of the Government of AP under the control of Energy, Infrastructure & Investment (E, I&I) department. APSFL aims to provide high quality & affordable digital services to households, government departments and enterprises across the State.

Fiber Grid is one of the 5 Grids identified by the Government of Andhra Pradesh to accelerate socio-economic growth of the State. Fiber Grid is primarily aimed at harnessing the power of information resource and enabling provision of qualitative and cost-effective IT, Communication (data, voice & video) and other related services to the citizens of A.P.

### **Vision of AP Fiber Grid is as follows:**

“To establish a highly scalable network infrastructure, accessible on a non-discriminatory basis, to provide on demand, affordable and end-to-end broadband connectivity of 15 Mbps for all households and 1 to 10 Gbps for institutions & multi-dwelling units by 2018, to enable realization of the Vision of Digital Andhra Pradesh, in partnership with the Government of India and Private Sector.” In line with the vision, a dual phased approach has been undertaken to deliver the project mandate in AP.

**Phase I** – Aerial Fiber Grid Network will create an aerial fiber network up-to Mandal level by leveraging assets of Electricity companies.

**Phase II** - Aerial Fiber network covering the entire State up to Gram Panchayats level.

Phase I of the Project (Aerial Fiber grid project), APSFL has established state-wide high speed optical fiber network infrastructure covering approximately 23,000 kms route across the 13 districts of Andhra Pradesh through 2449 PoPs being operated and controlled from Network Operations Centre (NOC) setup in Vishakhapatnam. Phase I project components include laying aerial optical Fiber across the State up to mandal level, so that the State, District, Zonal and Mandals are connected with each other using ring topology as much as possible. In addition, the last mile connectivity is to be made available through a network of MSOs/ LCOs.

APSFL has already procured the required CPE (customer premise equipment) boxes in order to deliver the Triple Play Services viz., Cable TV, high-speed Broadband and Telecom. Online enrolment of MSOs/LCOs for business association with APSFL have been done and has already extended Triple Play Services to thousands of customers through the CPE boxes procured.

APSFL proposes to establish OLA sites where the distance of transmission is more than 80Kms, to ensure effective service delivery without any signal drop issues.

In this regard, APSFL intends to procure OLA equipment with specifications provided (Annexure-IX) to optimize transmission.

**Existing Network Architecture:**

State-Wide Ring Topology

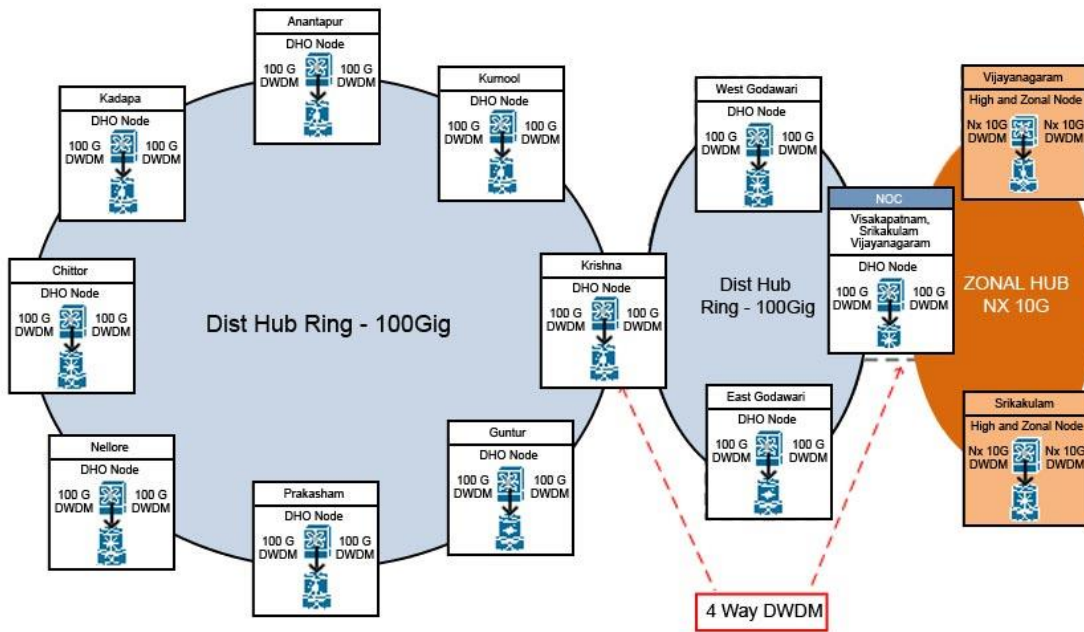

Network topology from District Hub (DHO) to End-User.

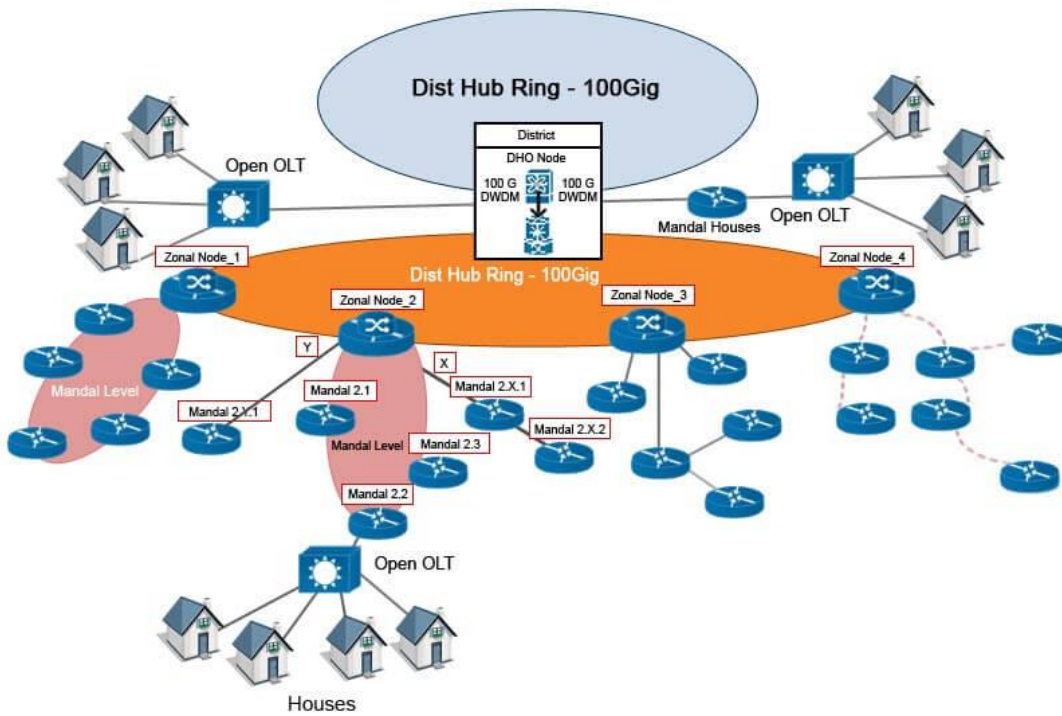

### 3. Scope of Work

Andhra Pradesh State FiberNet Limited intends to enhance the network capacity to provide Triple Play Services (Internet, Telephone, IPTV or CATV & other Value-Added Services) through the Fiber Network to Households and Enterprise Customers (Govt. Departments /PSU's/ Schools/Hospitals/Other Enterprises).

The existing aerial optical fibre cable laid by Andhra Pradesh State FiberNet Limited can result in significant signal loss when transmission distance increases more than certain limit.

In this regard, the selected bidder shall be responsible for the supply, installation and commissioning of the required Equipment and associated items at various sites/locations of APSFL in different parts of Andhra Pradesh and integration with the existing APSFL network for delivery of satisfactory services across the network. The selected bidder shall also carry out operation, Management and Maintenance of Supplied equipment for a period of five years from the date of Go-live. Therefore, the bidder is advised to procure sufficient spares in order to maintain SLAs.

#### 3.1 Delivery & Commissioning Phase

The scope of work in this phase comprises the following but not limited to:

- The selected bidder shall be responsible for the supply and installation of the required Software, Hardware/Accessories/SoftwareLicenses as per the Schedule of Requirement & Technical specifications of this RFP at locations mentioned within the stipulated time period as mentioned in this RFP.
- At least one engineer of OEM should remain at installation location for design, installation and configuration of the supplied equipment, during the complete installation period.
- APSFL will share the details/layouts of existing OFC network of respective locations with successful bidder and successful bidder will be responsible for installation and configuration of the supplied equipment.

The bidder shall be responsible for coordination with existing system integrator of APSFL for installation of 24F optical fibre cable at the required location, connecting both ends which includes, cable tapping from the OPGW to the Point of Presence.

- The NMS shall be installed and configured in consultation with APSFL
- All the software licenses shall be in the name of APSFL

The bidder shall be responsible for coordination with existing system integrator of APSFL for installation of UPS & Racks and Internal wiring with Earthing at the required locations.

The bidder shall be responsible for configurations where ever required to meet the requirements mentioned in the Schedule of Requirement.

The bidder shall be responsible to complete the work immediately for priority1. And Priority2 locations shall be completed upon submission of satisfactory performance certificate signed APSFL authorized representative within stipulated timelines by APSFL.

FROM POP	TO POP	Requirement
Bimadole _SRO & Substation Node	Vijayawada _dhq	Priority 1
Srisailam Right Bank _SDN	KURNOOL_DHQ	Priority 1
Anantapur_DHQ	RTPP_SRO	Priority 1
Vijayawada_DHQ	Sathenpalli _SRO	Priority 2
ELURU	VIZAG-NOC	Priority 2

### 3.2 User Acceptance Test

The primary goal of Acceptance Testing is to ensure that the work (including all the components as discussed in the scope of work) meets requirements, standards, specifications and performance, by ensuring that the following are associated with clear, quantifiable metrics for accountability:

- Infrastructure Compliance
- Performance
- Project Documentation

The Successful bidder shall inform the department in writing, as and when the work is completed for a specific work order, with the request to conduct UAT.

- a. APSFL may associate authorized personnel for UAT.
- b. The bidder shall co-ordinate and carry any other required test as desired by purchaser.
- c. The bidder shall bring all the testing equipment to site as required under the procedure to carry out testing at no extra cost.
- d. The time taken for approval of UAT acceptance by APSFL, shall not be considered as delay on bidder's part.
- e. The bidder is required to rectify the shortcomings reported, if any, during the testing. The selected bidder shall make the required changes at no extra cost.

### 3.3 Maintenance Phase

- The Successful bidder shall be responsible for configuration/re-configuration of all the equipment/services as and when required for 5 Years from date of Go-Live.
- The Successful bidder shall maintain a record of hardware and software configurations of all equipment including the details of different policies implemented on the devices such as DWDM configurations, routing, multiple protocol details etc. Successful bidder shall keep regular backups of soft copies of the configurations of each of the devices mentioned above.
- The successful bidder shall ensure that these configurations are not accessible in general and must be kept confidential with the Purchaser and Technical Resource
- Deputed technical resources shall also be responsible for the re-configuration of replaced devices.
- Tickets raised with OEM will be monitored by SPOC and SPOC shall share information about closure of ticket for SLA calculation.
- The bidder shall also provide an Escalation Matrix to APSFL for support cases.
- The Successful bidder shall carry out regular update and upgrade of firmware and software of the supplied equipment and NMS..

- Bidder shall ensure the periodic maintenance (at least quarterly) and submit the report to APSFL.

*The selected bidder has to understand the current solution in place and propose accordingly.*

#### 4. Pre-Qualification Criteria

The prospective bidders must satisfy the following eligibility criteria for submission of their bids and provide supporting documents as proof of eligibility.

S. No.	Prequalification Criteria	Documentary Proof to be submitted
1.	<p>The Lead Bidder/ consortium members should be a Company registered in India under the Indian Companies Act 1956/2013 or a Registered Partnership Firm or a Sole Proprietary Firm or LLP and should be in business for 3 FYs by the time of submission of the Bid.</p> <ul style="list-style-type: none"> <li>Foreign companies can be a consortium member provided they are manufacturer /OEM of the products being supplied.</li> </ul>	<ul style="list-style-type: none"> <li>In case the Bidder is a Registered Company in India, they should produce the copy of the Certificate of Incorporation.</li> <li>In case the Bidder is Registered Partnership Company / Firm, they should produce the copy of Registered Partnership Deed.</li> <li>In case the Bidder is a Sole Proprietary Firm, they should produce the copy of valid Tax Registration Certificate(s)</li> <li>Registration certificate under equivalent law abroad for foreign company</li> <li>A notarized or registered agreement between the Consortium members mentioning the details of Lead member and other consortium members and outline the financial strengths, technical strengths and the role and responsibility of each of the members of the consortium.</li> </ul>
2.	<p>The Bidder/ any consortium member should have at least 2 years of existence in manufacturing or supply of Equipment or similar products as on date of submission of RFP.</p>	<ul style="list-style-type: none"> <li>Copy of Purchase Orders/client certificate should be submitted.</li> <li>In the case of authorized distributor/dealer, a Letter of Authorization from the OEM/manufacture.</li> <li>In the case of OEM, the documentary proof for manufacturing the products.</li> </ul>
3.	<p>The Bidder/Consortium should have Average Annual Turnover of INR 5 Crores and above in last Three audited financial years from activities relating to IT Systems Integration services / IT services / Network services / Telecom services in India or abroad. In case of Consortium the prime bidder should contribute at least 50% of the turnover.</p>	<p>Copies of the Audited Balance sheets and Profit and Loss Accounts for the last 3 audited financial years (FY 15-16, FY 16-17 &amp; FY 17-18)</p>
4.	<p>Bidder / Consortium (all partners) should have positive net worth for the last 2 audited financial years.</p>	<p>Certificate from the Statutory Auditor or Practising Chartered Accountant for having positive net worth for the last 2 successive audited financial years (FY 16-17 &amp; FY 17-18)</p>
5.	<p>The Bidder / Consortium should have valid GST registration in India</p>	<p>Certified copy of valid GST registration certificates issued by competent authority in India. In case of consortium, this is applicable for all Indian members.</p>
6.	<p>The Bidder / Consortium should have ISO 9001 &amp; ISO 27001</p>	<p>Certified copy of ISO Certificates</p>

S. No.	Prequalification Criteria	Documentary Proof to be submitted
7.	The bidder/ consortium shall have experience of supplying, commissioning and providing support services for at least <b>50 Nos. DWDM</b> nodes in last 3 FYs in India.	Copy of Purchase Orders / Client Certificate should be submitted
8.	Power of Attorney / Board Resolution	Power of Attorney/Board Resolution authorizing the Tender Signing Authority
9.	The Bidder / Consortium should not have been blacklisted by any Govt or PSU in India as on the date of bid submission	Self-declaration by the bidder duly signed by the authorized signatory
10.	Technical compliance for the minimum specifications provided in scope of work	<ul style="list-style-type: none"> <li>• The bidder shall submit all the technical leaflets / technical literature / product certifications etc. to confirm the technical compliance.</li> <li>• The OEM should submit the compliance confirmation for each parameter in their letterhead and also MAF</li> <li>• If there is any deviation, the deviation with justification should be spelt out.</li> </ul>
11.	Existing service centres of OEM/ Authorized Distributors or Dealers in Andhra Pradesh	<ul style="list-style-type: none"> <li>• Should have at least one service centre in AP or Undertaking to establish the same within 90 days after receiving the workorder.</li> <li>• Self-certified declaration and address proof of service centres to be submitted.</li> </ul>

**Note:** In case of consortium, all correspondence related to this project shall be done with /through the lead member. Consortium cannot be more than two members.

## 5. Schedule of Requirement

Sr No	Item description	UoM	Quantity
<b>1</b>	<b>Supply and installation of Optical Line Amplifier NCS 2006</b>	<b>Nos.</b>	<b>5</b>
1.1	NCS 2000 Transport Node Controller w/2x OTDR/OSC	<b>Nos.</b>	<b>2</b>
1.2	SNTC-8X5XNBD NCS 2000 Transport Node Controller w/2x	<b>Nos.</b>	<b>2</b>
1.3	NCS 2K/MSTP - R10.7 SW, TNCE, TSCE, TNCS/O - WSON CP	<b>Nos.</b>	<b>2</b>
1.4	NCS 2006 Shelf Assembly	<b>Nos.</b>	<b>1</b>
1.5	SNTC-8X5XNBD NCS 2006 Shelf Assembly	<b>Nos.</b>	<b>1</b>
1.6	NCS 2006 LCD Display with Backup Memory	<b>Nos.</b>	<b>1</b>
1.7	Empty slot Filler Panel	<b>Nos.</b>	<b>4</b>
1.8	NCS 2006 Fan Tray	<b>Nos.</b>	<b>1</b>
1.9	NCS 2006 1,500W AC Power Supply	<b>Nos.</b>	<b>2</b>
1.10	NCS 2006 External Connections Unit	<b>Nos.</b>	<b>1</b>
1.11	Fiber patch cord - LC to LC - 2m	<b>Nos.</b>	<b>2</b>
1.12	15454 MSTP - Optical Amplifier - C-band - 24dB Gain	<b>Nos.</b>	<b>2</b>
1.13	SNTC-8X5XNBD 15454 MSTP - Optical Amplifier - C-band	<b>Nos.</b>	<b>2</b>
<b>2</b>	<b>Supply, fixing of wall mount 48 port FDMS with required trays and splicing of necessary patch cords</b>	<b>Nos.</b>	<b>5</b>
<b>3</b>	<b>EMS Licenses for OLA</b>	<b>Sets</b>	<b>5</b>



## 6. Technical Bid Evaluation

Sl. No.	Technical Criteria	Documentary Proof to be submitted	Compliance	Max Marks
1.	Cumulative Annual Turnover in last Three audited financial years. (FY 15-16, FY 16-17 & FY 17-18)	Copies of the Audited Balance sheets and Profit and Loss account	$\geq$ INR 5 Cr. & $\leq$ INR 10Cr.	<b>20</b>
			$>$ INR 10 Cr. & $\leq$ INR 15 Cr.	<b>25</b>
			$>$ INR 15 Cr.	<b>30</b>
2.	Positive net worth for the last 2 audited financial years.	Certificate from the Statutory Auditor / Practising Chartered Accountant for having positive net worth for the last 2 successive audited financial years (2016-17 & 2017-18)	100% for 2 Years	<b>10</b>
3.	Inter-Operability	Inter-Operability Testing with existing APSFL Network	100%	<b>10</b>
4.	Technical compliance to Equipment specifications	<p>The bidder shall submit all the technical leaflets / technical literature / product certifications etc. to confirm the technical compliance.</p> <p>The OEM should submit the compliance confirmation for each parameter for Equipment in letterhead.</p> <p>If there is any deviation, the deviation should be spelt out by the bidder in the OEM letter head.</p>	<p>Mandatory Compliance.</p> <p>Marking Schema:</p> <ul style="list-style-type: none"> <li>▪ Compliance with RFP specifications (decision of technical committee shall be final in award of full marks)</li> </ul>	<b>20</b>
5	The Bidder / Consortium should have ISO 9001 & ISO 27001	Certified copy of ISO Certificates		<b>15</b>
5.	The bidder/ consortium shall have experience of supplying, commissioning and providing support services for at least <b>50 Nos. DWDM nodes</b> in last 3 FYs in India.	Copy of purchase orders / client certificate should be submitted.	$\geq$ 50 Nos. & $<$ 70 Nos.	<b>10</b>
			$\geq$ 70 Nos. & $<$ 90 Nos.	<b>13</b>
			$\geq$ 90 Nos.	<b>15</b>

### Important Notes:

- Bidders should obtain **minimum 70 out of 100 marks** in the overall technical evaluation to qualify for opening of the Financial Bid.
- In case, none of the bidder achieves the min. qualifying marks, the Technical Evaluation Committee may revise the min. qualification marks as per the case in the interest of this RFP. The Technical Evaluation Committee's decision in this regard shall be final and binding on the Bidder.
- Bidders should submit necessary proofs towards experience claimed such as work orders / work completion certificates from clients/certificate from Auditors etc. as required by APSFL.
- APSFL may ask Bidder(s) for additional information to verify claims made in Bid documentation from already submitted Proposals at any point of time before announcement of final results.
- A Technical Committee will examine the Technical Bids against the Prequalification Criteria and Technical Criteria given in the Tender document and all other terms & conditions in the tender. The evaluation will be conducted based on the support documents submitted by the Bidders.

## 7. Instructions to the Bidder

### 7.1 General

1. The Bidders are requested to examine the instructions, terms and conditions and specifications given in the Tender. Failure to furnish all required information in every respect will be at the Bidder's risk and may result in the rejection of bid.
2. It will be imperative for each Bidder(s) to familiarize itself/ themselves with the prevailing legal situations for the execution of contract. APSFL shall not entertain any request for clarification from the Bidder regarding such legal aspects of submission of the Bids.
3. It will be the responsibility of the Bidder that all factors have been investigated and considered while submitting the Bids and no claim whatsoever including those of financial adjustments to the contract awarded under this tender will be entertained by APSFL. Neither any time schedule nor financial adjustments arising thereof shall be permitted on account of failure by the Bidder to appraise themselves.
4. The Bidder shall be deemed to have satisfied itself fully before Bidding as to the correctness and sufficiency of its Bids for the contract and price quoted in the Bid to cover all obligations under this Tender.
5. It must be clearly understood that the Terms and Conditions and specifications are intended to be strictly enforced. No escalation of cost in the Tender by the Bidder will be permitted throughout the period of Agreement or throughout the period of completion of contract whichever is later on account of any reasons whatsoever.
6. The Bidder should be fully and completely responsible to APSFL and State Government for all the deliveries and deliverables. .

### 7.2 Pre-bid Queries

All enquiries from the Bidders relating to this RFP must be submitted to the Executive Director (Technical), APSFL, Vijayawada. These queries should be e-mailed in MS-Excel format to [apsfl@ap.gov.in](mailto:apsfl@ap.gov.in). The queries should necessarily be submitted in the following Format:

#	RFP Part No.	Section No.	Page no.	Content of the RFP requiring clarification	Clarification Sought

### 7.3 Language of the Bid

The bids prepared by the Bidder and all subsequent correspondence and documents relating to the bids exchanged by the Bidder and APSFL shall be written in **English** language. Any printed literature furnished by the Bidder, written in another language, shall be accompanied by an accurate English translation, in which case, for purposes of interpretation of the Bid, the English translation shall govern.

## 7.4 Amendments

Before closing of the Tender, clarifications and amendments if any will be notified in the website mentioned in the Tender Schedule. The Bidders periodically check for the amendments or corrigendum or information in the website till the closing date of this Tender. APSFL will not make any individual communication and will in no way be responsible for any ignorance pleaded by the Bidders.

Before the closing of the Tender, APSFL may amend the Tender document as per requirements or wherever APSFL feels that such amendments are necessary.

Amendments also may be given in response to the queries by the prospective Bidders. Such amendments will be notified in the websites mentioned in the tender schedule. APSFL at its discretion may or may not extend the due date and time for the submission of bids on account of amendments.

APSFL is not responsible for any misinterpretation of the provisions of this tender document on account of the Bidders failure to update the Bid documents on changes announced through the website..

## 7.5 Clarifications by APSFL

When deemed necessary, APSFL may seek bonafide clarifications on any aspect from the Bidder. However, that would not entitle the Bidder to change or cause any change in the substance of the Bid or price quoted. During the course of Technical Bid evaluation, APSFL may seek additional information or historical documents for verification to facilitate decision making. In case the Bidder failed to comply with the requirements of APSFL as stated above, such Bids may at the discretion of APSFL, shall be rejected as technically non-responsive.

## 7.6 Suppression of facts and misleading information

During the Bid evaluation, if any suppression or misrepresentation of is brought to the notice of APSFL. APSFL shall have the right to reject the Bid and if after selection, APSFL would terminate the contract, as the case may be, will be without any compensation to the Bidder and the EMD / PBG, as the case may be, shall be forfeited.

Bidders should note that any figures in the proof documents submitted by the Bidders for proving their eligibility is found suppressed or erased, APSFL shall have the right to seek the correct facts and figures or reject such Bids.

It is up to the Bidders to submit the full copies of the proof documents to meet out the criteria. Otherwise, APSFL at its discretion may or may not consider such documents.

Tender calls for full copies of documents to prove Bidder's experience and capacity to undertake the project.

## 7.7 Contacting Tender Inviting Authority

Bidders shall not make attempts to establish unsolicited and unauthorized contact with APSFL /Tender Committee after the opening of the Tender and prior to the notification of the Award and any attempt by any Bidder to bring to bear extraneous pressures on the Tender Accepting Authority shall be sufficient reason to disqualify the Bidder.

Notwithstanding anything mentioned above, APSFL may seek bonafide clarifications from Bidders relating to the tenders submitted by them during the evaluation of tenders.

## **7.8 Tender Validity**

The offer submitted by the Bidders should be valid for a minimum period of 180 days from the date of opening of the Tender.

## **7.9 Hand written documents, Erasures or Alterations**

The offers containing erasures or alterations will not be considered. There should be no hand-written material, corrections or alterations in the offer. Filling up of the information using terms such as “OK”, “noted”, “as given in brochure/manual” is not acceptable and may lead to the disqualification of the Bid.

## **7.10 Bid Prices**

The Bidder shall indicate in the proforma prescribed, the unit rates and total Bid Prices for the equipment / services, it proposes to provide under the Contract. Prices should be shown separately for each item as detailed in this document.

If during the course of execution of the project any minor revisions to the work requirements like technical specifications, equipment sizing, etc. are to be made to meet the goals of the Project; such changes shall be carried out within the proposed price. If any deviation has a major impact on the Project Cost, the Authority shall take appropriate decision and such decisions would be binding on the Bidder.

Prices quoted in the Bid must be firm and final and shall not be subject to any modifications, on any account whatsoever. The Bid Prices shall be indicated in Indian Rupees (INR) only.

The Price Bid should clearly indicate the price quoted without any ambiguity / qualifications whatsoever and should include all applicable duties, fees, levies, and other charges as may be applicable in relation to the activities proposed to be carried out. Taxes as applicable shall be paid by APSFL.

Prices in any form or by any reason before opening the Price Bid should not be revealed, failing which the offer shall be liable for rejection. If price change is inevitable due to any factor external to the bidders, the bidders may be given chance to submit revised Bids in a separate sealed cover. Decisions of the Authority shall be final in this regard.

## **7.11 Letter of Authorization**

A letter of Authorization from the Board of Directors / appropriate authority authorizing the Tender submitting authority or a Power of Attorney should be scanned and submitted in the Tender, otherwise the Bids will be summarily rejected.

## **7.12 Conditional Bids/Offer by the Bidders**

The Bidder should abide by all terms and conditions specified in the RFP Document. Conditional bids/offers shall be liable for disqualification.

## **7.13 Late Tender Bids**

Any tender offer received by APSFL after the deadline for submission of tender offer prescribed by the Authority, will be summarily rejected.

## 7.14 Opening of Bids

Bids received within the prescribed closing date and time will be opened at APSFL Head Office, Vijayawada, on the date, time and at the address mentioned in the RFP Documents.

Price Bid of only those Bidders who fulfilled all the eligibility criteria shall be opened.

## 7.15 Right to Accept or Reject Bids

Authority reserves the right to accept or reject any Bid, and to annul the RFP process and reject all bids at any time prior to award of contract, without thereby incurring any liability to the affected Bidder(s) or any obligation to inform the affected Bidder(s) of the grounds for such action.

## 7.16 Notification of Award

Authority will notify the Successful Bidder via letter / fax /email of its intent of accepting the bid. Within 7 days of receipt of the Letter of Acceptance (LoA) issued by the Authority, the Successful Bidder shall be required to sign the LoA and return the same to the address specified above as a token of acceptance of the LoA.

## 7.17 Earnest Money Deposit

An EMD amount as specified in the Tender Schedule should be paid by way of Bank Guarantee drawn in favour of “Andhra Pradesh State FiberNet Limited” payable at Vijayawada valid for 210 days from date of Submission.

The EMD of the unsuccessful Bidders will be returned at the expense of the Bidders within a reasonable time consistent with the rules and regulations in this behalf. The EMD amount held by APSFL till it is refunded to the unsuccessful Bidders will not earn any interest thereof.

The EMD amount of the Successful Bidder(s) can be converted as part of Security Deposit (SD) for successful execution of the work and will be returned only after the successful fulfilment of the Contract.

The EMD amount will be forfeited by APSFL, if the Bidder withdraws the bid during the period of its validity specified in the tender or if the Successful Bidder fails to sign the contract or the Successful in bidder fails to remit Security Deposit within the respective due dates.

<b>Name of Beneficiary</b>	Andhra Pradesh State Fibernet Limited
<b>Name of Bank</b>	Andhra Bank
<b>Bank address</b>	Andhra Bank, Main Branch, RR Apparao street, Vijayawada, Andhra Pradesh
<b>Bank Account No</b>	100611100002032
<b>IFSC CODE</b>	ANDB0000606
<b>MICR CODE</b>	520011025
<b>BRANCH CODE</b>	000606

## 7.18 Performance Bank Guarantee

As a condition precedent to execution of the Agreement, the Successful Bidder shall ensure submission of the requisite unconditional irrevocable Bank Guarantee, in the prescribed Format within 15 days of receipt of the LOA as a Performance Bank Guarantee (PBG) for **10% of the Contract Value** for the services to be performed under the resultant Agreement. The Performance Bank Guarantee shall be valid for the term of the

resultant Agreement + 3 months and shall be renewed and maintained as necessary by the SI for the term of the resultant Agreement, and extensions if any. In case of any delay/ non-submission of PBG, decision of APSFL shall be final & binding on the bidder.

Earnest Money Deposits (EMD) submitted by the bidders along with their bids shall be refunded to all bidders, except the Successful Bidder, within 30 days of issuance of the LOI. EMD of the successful bidder will be considered towards PBG and validity should be extended as per the contract duration.

The Performance Bank Guarantee may be liquidated by the Authority as penalty/liquidated damages resulting from the Successful bidder's failure to complete its obligations under the resultant Agreement. The Performance Bank Guarantee shall be returned by Authority to the Bidder within 120 days of the term/expiration of the resultant Agreement after applicable deductions as per the Agreement, if any.

### **7.19 Signing of Agreement**

Subsequent to Authority notification to the Successful Bidder by way of a LoA, acceptance of the LoA and submission of the Performance Guarantee, the Successful Bidder shall execute the Agreement with the APSFL. Failure of the Successful Bidder to furnish the Performance Guarantee or execute the Agreement within the prescribed time shall cause the EMD of the Successful Bidder to be liquidated. In such event, APSFL shall negotiate with the next eligible bidder. The Successful Bidder will be liable to indemnify APSFL for any additional cost or expense, incurred on account of failure of the Successful Bidder to execute the Agreement.

Not with standing anything to the contrary mentioned above, the Authority at its sole discretion shall have the right to extend the timelines for execution of Agreement on the request of the Successful Bidder, provided the same is bonafide.

### **7.20 Rejection Criteria**

Besides other conditions and terms highlighted in the RFP Document, bids may be rejected under following circumstances:

- a) Conditional Bids.
- b) If the information provided by the Bidder is found to be incorrect / misleading / fraudulent at any stage / time during the RFP Evaluation Process.
- c) Any effort on the part of a Bidder to influence the bid evaluation, bid comparison or contract award decisions.
- d) Bids received after the prescribed time & date for receipt of bids.
- e) Bids without signature of person (s) duly authorized on required pages of the bid.
- f) Bids without power of attorney/ board resolution or its certified true copy.
- g) Bids received without submission of the prescribed Bid processing fee/EMD.
- h) Incomplete Price Bid.
- i) Price Bids that do not conform to the RFP's Price Bid Format.
- j) If there is an arithmetic discrepancy in the Price Bid calculations the RFP Evaluation Committee shall rectify the same. If the Bidder does not accept the correction of the errors, its Bid may be rejected.

### **7.21 Concessions permissible under statutes**

Bidder, while quoting against this RFP, must take cognizance of all concessions permissible, if any, under the statutes and ensure the same is passed on to the Authority, failing which it will have to bear extra cost. In case Bidder does not avail concessional rates of levies like customs duty, excise duty, sales tax, etc. APSFL

will not take responsibility towards this. However, the Authority may provide necessary assistance, wherever possible, in this regard.

## 7.22 Bid forms

- a. Wherever a specific form is prescribed in the bid document, the bidder shall use the form to provide relevant information.
- b. For all other cases the bidder shall design a form to hold the required information.

## 7.23 Delivery Timelines

The Successful Bidder shall complete the work for 3 locations immediately within in 60 days and other 2 locations within stipulated timelines by APSFL. If the Successful Bidder fails to commence the assignment, the LOA may be, cancelled /terminated.

However, in case of specific reasons for delay in supply beyond the periods specified herein the bidder should obtain specific written approval from APSFL citing the reasons. The decision of APSFL is final on the issue of extension of the delivery period.

## 7.24 Delivery & Documents

Delivery of Goods and Services shall be made by the selected vendor strictly in accordance with the specifications of the tender document or in case of deviations, the specifications approved and accepted by APSFL. Corresponding documentation shall be submitted to APSFL along with delivery.

Delivery to the designated locations or central warehouse of APSFL is responsibility of the selected bidder.

Successful bidder should maintain adequate spares to support at least 10% of equipment supplied as part of this RFP.

## 7.25 Third Party Claims

The selected bidder shall indemnify APSFL against all third-party claims of infringement of patent, trademark or industrial design rights arising from use of the Goods or any part thereof in India.

## 7.26 Inspection & Test

APSFL and/or its representative reserve the right of inspection and testing of the goods prior to delivery and after delivery at the site, or at any time during the period of the contract.

APSFL reserves the right to inspect, test and, wherever necessary, reject the Goods after the Good's arrival at Project Site. This shall in no way be limited or waived by reason of the Goods having previously been inspected, tested and passed by APSFL or its representative prior to the Goods shipment.

## 7.27 Execution of Work Order

The Successful Bidder should nominate and intimate APSFL, an Account Manager for Single Point of Contact (SPOC), who should be responsible for effective delivery of work complying with all the terms and conditions. The Successful Bidder should ensure that the Account Manager fully familiarizes with the Tender Conditions, Scope of Work and deliverables.

## 7.28 Service Levels and Warranty & Maintenance

Bidder is required to provide the Comprehensive Onsite upfront warranty & Maintenance of Five years from GO-Live whichever. The warranty shall be counted from the date of commissioning. It is also required to properly maintain sufficient spare parts for all supplied equipment to meet the required SLA. The details of the work to be undertaken are as follows:

- Diagnosis of the fault
- Repairing of defective parts/components.
- Replacement of parts/components beyond repair with parts/components of same or better specifications ensuring compatibility.
- Providing suitable standby for parts/components with same or better specifications till the time the original part/component is repaired or replaced so that daily business is not affected.
- Submit a list containing the details of the delivered equipment including Serial Numbers, Model Name & Make, etc. to APSFL during delivery of the equipment (along with the Delivery Challan). The details of the delivered equipment shall also be updated in the Warranty Management System of the OEM.

S.No	Complaint Category	TTR(Time to Repair in Hrs)	Penalty for each ticket per Hour after Agreed SLA (INR)
1	Critical	Within 4 Hrs	Rs.500
2	Major	Within 6 Hrs (9am to 9pm, excluding Sunday and National Holidays)	Rs.200
3	Minor	6 Working Days	Rs.100

Beyond Rs.75,000/- of penalty in a quarter, for delays exceeding the SLA, action will be initiated as per the APSFL policy.

- i. The average downtime (fault restoration time) of faulty Equipment will be taken as reference for define the severity level and the penalty.
- ii. Critical - Interruption making a critical functionality inaccessible or a complete network interruption causing a severe impact on services availability. There is no possible alternative.
- iii. Major- Critical functionality or network access interrupted, degraded or unusable, having a severe impact on services availability. No acceptable alternative is possible.
- iv. Minor - Non-critical function or procedure, unusable or hard to use having an operational impact, but with no direct impact on services availability. A workaround is available.

For the purpose of calculating SLA, the following faults or outage hours shall be excluded:

- i. Periods where the APSFL/customer is inaccessible to confirm the status of the system after fault clearance by the vendor.
- ii. Periods where any IPTV/Triple Play box is switched off at the customer end due its own reasons. The onus lies on APSFL to ensure that the on-site equipment is Powered ON and / or the Network



Monitoring tools, if any, that are used by APSFL should be able to filter out the time period of box being voluntarily switched off, from the Down Time calculations.

- iii. Periods where the failure of any components or equipment belonging to APSFL/Customer.
- iv. The time lost in attending to a complaint due to delay in entering APSFL's/customer's premises shall not be considered as a down time. The SLA document will be reviewed for any changes/amendments that are deemed necessary by APSFL during the one-year warranty period.

## 7.29 Payment Terms

1. 30% of total value payable against successful delivery of the equipment within 30 days from submission of invoice.

Deliverable – Delivery challans duly signed by APSFL

2. 60% of the total value payable against successful Go-Live & Acceptance from APSFL.

Deliverable – Acceptance certificate duly signed by APSFL

3. 10% of the total value will be given after 3 months from date of Go-Live and upon satisfactory certification from APSFL.

Deliverable – Satisfactory certificate duly signed by APSFL

## 7.30 Force Majeure

Force Majeure shall not include any events caused due to acts/omissions of such Party or result from a breach/contravention of any of the terms of the Contract, Bid and/or the Tender. It shall also not include any default on the part of a Party due to its negligence or failure to implement the stipulated/proposed precautions, as were required to be taken under the Agreement.

The failure or occurrence of a delay in performance of any of the obligations of either party shall constitute a Force Majeure event only where such failure or delay could not have reasonably been foreseen or where despite the presence of adequate and stipulated safeguards the failure to perform obligations has occurred. In such an event, the affected party shall inform the other party in writing within five days of the occurrence of such event.

APSFL will make the payments due for Services rendered till the occurrence of Force Majeure. However, any failure or lapse on the part of the vendor in performing any obligation as is necessary and proper to negate the damage due to projected force majeure events or to mitigate the damage that may be caused due to the above-mentioned events or the failure to provide adequate disaster management/recovery or any failure in setting up a contingency mechanism would not constitute force majeure, as set out above.

In case of a Force Majeure all Parties will endeavour to agree on an alternate mode of performance in order to ensure the continuity of service and implementation of the obligations of a party under the agreement and to minimize any adverse consequences of Force Majeure.

## 7.31 Liquidated Damages

Subject to clause for Force Majeure if the bidder fails to complete before the scheduled date or if bidder repudiates the agreement before completion of the Work, APSFL at its discretion may without prejudice to

any other right or remedy available to APSFL the Contract recover a maximum of 5% (five percent) of the total value of the work order from the successful bidder as Liquidated Damages (LD).

1% of the late delivered or deemed late delivered/installed deliveries/installations goods for One week or part thereof, 1.5% for Two weeks or part thereof, 2% for Three weeks or part thereof, 2.5% for 4 weeks or part thereof and so on subject to maximum of 5%. If the delay continues beyond 10 weeks, APSFL may terminate the Agreement.

APSFL may without prejudice to its right to effect recovery by any other method deduct the amount of liquidated damages from any money belonging to the bidder in its hands (which includes APSFL's right to claim such amount against successful bidder's Bank Guarantee) or which may become due to the Implementation Agency. Any such recovery or liquidated damages shall not in any way relieve the bidder from any of its obligations to complete the Works or from any other obligations and liabilities under the agreement.

## **7.32 Termination of Contract**

### **Termination for default**

APSFL may without prejudice to any other remedy for breach of contract, by written notice of default with a notice period of 7 days, sent to the Successful Bidder, terminate the contract in whole or part,

- (i) If the Successful Bidder fails to deliver any or all of the goods within the time period(s) specified in the Contract, or fails to supply the items as per the Delivery Schedule or within any extension thereof granted by APSFL; or
- (ii) if the Successful Bidder fails to perform any of the obligation(s) under the contract; or
- (iii) if the Successful Bidder, in the judgement of APSFL, has engaged in fraudulent and corrupt practices in competing for or in executing the Contract.

In the event APSFL terminates the Contract in whole or in part, APSFL may procure, upon terms and in such manner as it deems appropriate, the goods and services similar to those and delivered and the Successful Bidder shall be liable to APSFL for any additional costs for such similar goods. However, the Successful Bidder shall continue the performance of the contract to the extent not terminated.

### **Termination for Insolvency**

APSFL may at any time terminate the Contract by giving written notice with a notice period of 7 days to the Successful Bidder. If the Successful Bidder becomes bankrupt or otherwise insolvent. In this event, termination will be without compensation to the Successful Bidder, provided that such termination will not prejudice or affect any right of action or remedy that has accrued or will accrue thereafter to APSFL.

### **Termination for Convenience**

APSFL may by written notice, with a notice period of seven days sent to the Successful Bidder, may terminate the Contract, in whole or in part, at any time for its convenience. The notice of termination shall specify that termination is for APSFL's convenience, the extent to which performance of work under the Contract is terminated, and the date upon which such termination becomes effective. On termination, the successful Bidder is not entitled to any compensation whatsoever.

### **7.33 Arbitration and Jurisdiction**

In case of any dispute, the matter will be referred to a Sole Arbitrator to be appointed by the Managing Director of APSFL in accordance with the "Arbitration and Conciliation Act 1996". The arbitration shall be held in Vijayawada, India and the language English only.

Subject to the above, the Courts of AP alone only shall have jurisdiction in the matter.

## 8. Annexures

### 8.1 Checklist

Sl. No.	Documents	Compliance (Yes/No)
1	Cover Letter as per given format	
2	Bidder Profile as per given format	
3	Financial Information as per given format	
4	Declaration of acceptance of RFP terms and conditions	
5	Declaration of clean track record / No Blacklisting	
6	Price Bid as per given format	
7	In case the Bidder is a Registered Company in India, they should produce the copy of the Certificate of Incorporation.	
8	In case the Bidder is Registered Partnership Company / Firm, they should produce the copy of Registered Partnership Deed.	
9	In case the Bidder is a Sole Proprietary Firm, they should produce the copy of valid Tax Registration Certificate(s)	
10	Registration certificate under equivalent law abroad for foreign company	
11	A notarized or registered agreement between the Consortium members mentioning the details of Lead member and other consortium members and outline the financial strengths, technical strengths and the role and responsibility of each of the members of the consortium.	
13	Copy of Purchase Orders/client certificate should be submitted	
15	In the case of authorized distributor/dealer, a Letter of Authorization from the OEM/manufacture.	
16	In the case of OEM, the documentary proof for manufacturing the products.	
17	Copies of the Audited Balance sheets and Profit and Loss Accounts for the last 3 audited financial years	
18	Certificate from the Statutory Auditor / Practicing Chartered Accountant for having positive net worth for the last 2 successive audited financial years	
19	Certified copy of valid GST registration certificates issued by competent authority in India. In case of consortium, this is applicable for all Indian members.	
20	Power of Attorney / Board Resolution authorizing the Tender Signing Authority	
21	The bidder shall submit all the technical leaflets / technical literature / product certifications etc. to confirm the technical compliance.	
22	The OEM should submit the compliance confirmation for each parameter in their letterhead and also MAF	
23	If there is any deviation, the deviation with justification should be spelt out.	
24	Should have at least one service centre in AP or Undertaking to establish the same within the timelines stipulated by APSFL.	
25	Self-certified declaration and address proof of service centres to be submitted.	

## 8.2 Annexure I – Cover Letter

(To be submitted by Bidder on Original Letterhead)

To

[Date]

The Managing Director,  
Andhra Pradesh State FiberNet Limited,  
3rd Floor, NTR Administrative Block,  
Pandit Nehru Bus Station, NH – 65, Vijayawada – 520013

**Subject: Supply, Installation & Maintenance of Cisco Optical Line Amplifiers for AP Fiber Grid Phase I**

**Ref. No. APSFL/OLA/284-1/2018, Dated 02/03/2019**

Dear Sir,

With reference to your RFP Document dated ..... I/We, having examined all relevant documents and understood their contents, hereby submit our Proposal.

1. All information provided in the Proposal and in the Appendices, is true and correct and all documents accompanying such Proposal are true copies of their respective originals.
2. I/We shall make available to the Authority any additional information it may deem necessary or require for supplementing or authenticating the Proposal.
3. I/We acknowledge the right of the Authority to reject our Proposal without assigning any reason or otherwise and hereby waive our right to challenge the same on any account whatsoever.
4. I/We to the best of our knowledge certify that in the last three years, we or any of our Associates have neither failed to perform on any contract, as evidenced by imposition of a penalty by an arbitral or judicial authority or a judicial pronouncement or arbitration award against the Bidder, nor been expelled from any project or contract by any public authority nor have had any contract terminated by any public authority for breach on our part.
5. I/We understand that you may cancel the Selection Process at any time and that you are neither bound to accept any Proposal that you may receive nor to select the vendor, without incurring any liability to the Bidders
6. I/We to the best of our knowledge certify that in regard to matters other than security and integrity of the country, we or any of our Associates have not been convicted by a Court of Law or indicted or adverse orders passed by a regulatory authority which would cast a doubt on our ability to undertake the Project or which relates to a grave offence that outrages the moral sense of the community.
7. I/We to the best of our knowledge further certify that in regard to matters relating to security and integrity of the country, we have not been charge-sheeted by any agency of the Government or convicted by a Court of Law for any offence committed by us or by any of our Associates.
8. I/We agree and understand that the Proposal is subject to the provisions of the RFP document. In no case, shall I/We have any claim or right of whatsoever nature if our Proposal is not opened or rejected.
9. I/We agree to keep this offer valid for 180 days from the Proposal Due Date specified in the RFP.

10. I/We agree and undertake to abide by all the terms and conditions of the RFP Document. In witness thereof, I/We submit this Proposal under and in accordance with the terms of the RFP Document.

Yours faithfully,

(Signature, name and designation of the authorized signatory)

(Name and seal of the firm)

### 8.3 Annexure II – Bidder Profile

(To be submitted by Bidder on original letterhead)

#	Particulars	Details
1.	Name of the Company	
2.	Year of incorporation	
3.	Nature of the Company (Registered Company)	
4.	<b>Registered Office Address</b>	
	Office Telephone Number	
	Fax Number	
5.	<b>Contact Person</b>	
	Name	
	Telephone Number	
	Email Address	
6.	<b>Local presence at Andhra Pradesh</b>	
	Office Address	
	Office Telephone Number	
	Fax Number	
7.	<b>Contact Person (in Andhra Pradesh)</b>	
	Name	
	Telephone Number	
	Email Address	
8.	<b>Registration Details</b>	
	Permanent Account Number (PAN)	
	VAT Registration Number	
	CST Registration Number	
	Service Tax Registration Number	
	GST Number	
9.	Banker's Name, Address and Account Number	

### 8.4 Annexure III - Financial Information

(To be submitted by Bidder on original letterhead)

#### Annual Turnover of the Bidder(s)

Criteria	Sub Criteria	FY	Total Financials
Financial Capability	Avg. Annual Turnover (in INR)	FY 2015-16	
		FY 2016-17	
		FY 2017-18	
	Net worth	FY 2016-17	
		FY 2017-18	

***Documentary Proof Required:***

- Statutory auditor's certificate clearly specifying the Turnover & Net worth for the specified years.
- Audited Balance Sheets and Profit & Loss statements for the last 3 financial years as on 31.03.2018
- In Case of Audited balance sheets for 2017-18 are not available provisional balance sheets may be submitted.

## 8.5 Annexure IV- Declaration of Acceptance of RFP Terms & Conditions

(To be submitted by Bidder on original letterhead)

To,

[Date]

The Managing Director,

Andhra Pradesh State FiberNet Limited,

3rd Floor, NTR Administrative Block,

Pandit Nehru Bus Station, NH – 65, Vijayawada – 520013

**Subject: Supply, Installation & Maintenance of Cisco Optical Line Amplifiers for AP Fiber Grid Phase I**

**Ref. No. APSFL/OLA/284-1/2018, Dated 02/03/2019**

Sir,

It is to certify that the RFP document – RFP No..... dated..... is carefully read & understood and all the sections and clauses are **COMPLIED UNCONDITIONALLY AND UNEQUIVOCALLY**. There is no deviation from the terms & conditions of the RFP. We also hereby confirm that the solution proposed by us will meet the project requirements.

Yours faithfully,

(Signature, name and designation of the authorized signatory)

(Name and seal of the firm)



## 8.6 Annexure V - Declaration of Clean Track Record/ No Blacklisting

(To be submitted by Bidder on original letterhead)

To,

[Date]

The Managing Director,  
Andhra Pradesh State FiberNet Limited,  
3rd Floor, NTR Administrative Block,  
Pandit Nehru Bus Station, NH – 65, Vijayawada – 520013.

**Subject: Supply, Installation & Maintenance of Cisco Optical Line Amplifiers for AP Fiber Grid Phase I**

**Ref. No. APSFL/OLA/284-1/2018, Dated 02/03/2019**

Sir,

I/We hereby declare that my company has not been debarred / black listed as on Bid submission date by any State Government, Central Government, Central & State Govt. Undertakings / Organizations and by any other Quasi Government bodies / Organizations, and any other major Enterprise / Organizations in India for non-satisfactory past performance, corrupt, fraudulent or any other unethical business practices.

Yours faithfully,

(Signature, name and designation of the authorized signatory)

(Name and seal of the firm)

## 8.7 Annexure VI -EMD Format

(To be executed in Rs.100/- Stamp Paper)

To,  
 The Managing Director,  
 Andhra Pradesh State FiberNet Limited,  
 3rd Floor, NTR Administrative Block,  
 Pandit Nehru Bus Station,  
 NH – 65, Vijayawada – 520013

Bank Guarantee No:  
 Amount of Guarantee:  
 Guarantee covers from:  
 Last date for lodgement of claim:

This Guarantee executed by \_\_\_\_\_ (Banker's Name & Address) having our Head Office at \_\_\_\_\_ (address) (hereinafter referred to as "Bank") in favour of Andhra Pradesh State FiberNet Limited NTR Administrative Block, 3rd Floor, Pandit Nehru Bus Station, NH -65, Vijayawada – 520013 India (hereinafter referred to as "Beneficiary") for an amount not exceeding Rs. \_\_\_\_\_/- (Rupees \_\_\_\_\_ Only) as per the request of M/s. \_\_\_\_\_ having its office address at \_\_\_\_\_ (hereinafter referred to as "Bidder") against RFP reference \_\_\_\_\_ dated \_\_\_\_/\_\_\_\_/\_\_\_\_ of M/s. Andhra Pradesh State FiberNet Limited (APSFL). This guarantee is issued subject to the condition that the liability of the Bank under this guarantee is limited to a maximum of Rs. \_\_\_\_\_/- (Rupees \_\_\_\_\_ Only) and the guarantee shall remain in full force up to \_\_\_\_\_ (date) and cannot be invoked otherwise by a written demand or claim by the beneficiary under the Guarantee served on the Bank before \_\_\_\_\_ (date).

ANDWHEREAS it has been stipulated by you in the said ORDER that the Supplier shall furnish you with a Bank Guarantee by a Scheduled/Nationalized Bank for the sum specified therein as EMD towards bid submission.

ANDWHEREAS we have agreed to give the Bidder a Guarantee.

THEREFORE, we (Bankers address) \_\_\_\_\_, hereby affirm that we are Guarantors and responsible to you on behalf of the Bidder for Rs. \_\_\_\_\_/- (Rupees \_\_\_\_\_ Only) and we undertake to pay you, upon your first written demand without any demur, cavil or argument, any sum or sums within the limit of Rs. \_\_\_\_\_/- (Rupees \_\_\_\_\_ Only) as aforesaid, without your needing to prove or show grounds or reasons for your demand or the sum specified therein. We will pay the guaranteed amount notwithstanding any objection or dispute whatsoever raised by the Bidder.

This Guarantee is valid until \_\_\_\_\_.

Place:

Date:  
 (Bank)

Signature and seal of Guarantors

### 8.8 Annexure VII – Performance Bank Guarantee Format

(To be submitted by the successful bidder on Rs.100/- stamp paper)

In consideration of APSFL (“Authority”), having agreed to accept from \_\_\_\_\_ “successful bidder”, a Performance Bank Guarantee as maybe modified from time to time wherever necessary under the terms and conditions of the Agreement entered into by the said successful bidder in respect of work \_\_\_\_\_, RFP No. \_\_\_\_\_ under APSFL for the due fulfilment of the terms and conditions of the said Agreement under APSFL, on production of a Bank Guarantee for Rs.\_\_\_\_ (Rupees \_\_\_\_\_ only), we “Bank” \_\_\_\_\_ branch, hereby undertake the guarantee to pay immediately to APSFL, on demand in writing by APSFL, an amount of Rs. \_\_\_\_\_ (Rupees \_\_\_\_\_) without any reservation and recourse against any loss or damage caused to or suffered by APSFL by reason of any breach by the successful bidder of any of the terms and conditions of the said agreement under the said Authority.

We \_\_\_\_\_ Bank, further agree that the guarantee hereby contained shall remain in full force and effect during the period that will be taken for the performance of the said Agreement under the APSFL and that it shall be in enforcement until all the dues of APSFL under or by virtue of the said Agreement under the APSFL have been fully paid and their claims satisfied or discharged or until the said Authority certifies that the terms and conditions of the said Agreement under the APSFL have been fully and properly carried out by the successful bidder and accordingly discharges the guarantee subject. This bank guarantee is valid till \_\_\_\_\_ (date) and APSFL shall have no rights under this guarantee after \_\_\_\_\_ (date).

We \_\_\_\_\_ Bank, lastly undertake not to revoke this guarantee during its currency except with the previous consent of the APSFL in writing.

Dated \_\_\_\_\_ day of \_\_\_\_\_ 2019.

Place:

Date:  
(Bank)

Signature and seal of Guarantors

## 8.9 Annexure VIII- Manufacturer's Authorization Form (MAF)

(To be submitted in Manufacturer's letterhead)

To  
The Managing Director,  
Andhra Pradesh State FiberNet Limited,  
3rd Floor, NTR Administrative Block,  
Pandit Nehru Bus Station, NH – 65, Vijayawada – 520013

Sir,

We hereby authorize M/s \_\_\_\_\_ to undertake to submit a Bid, and subsequently negotiate & sign the contract with APSFL for the Tender No: \_\_\_\_\_ for product manufactured by us. We hereby extend our full warranty for the goods offered for supply by the above firm against this tender.

We also undertake to provide timely supplies as per terms of tender and as agreed mutually and also to provide a trouble free and continuous support either directly or through our authorized distributors/dealers under our supervision during the said support period. We will provide the necessary support in the event of up gradation of any of the software is necessitated while providing the support will arrange for complete replacement of the item(s) with an equivalent / higher version.

**In case of violation of any of the conditions above, I/We understand that I/We are liable to be blacklisted by APSFL for a period of three years.**

(Signature of authorized Personnel)

**Note:** Competent authority of the Manufacturer should issue the letter of authority individually for each bidder separately.

## 8.10 Annexure IX – Price Bid Form

(To be submitted by Bidder on original letterhead)

To  
 The Managing Director,  
 Andhra Pradesh State FiberNet Limited,  
 3rd Floor, NTR Administrative Block,  
 Pandit Nehru Bus Station,  
 NH – 65, Vijayawada – 520013

Date:

**Subject: Supply, Installation & Maintenance of Cisco Optical Line Amplifiers for AP Fiber Grid Phase I**

**Ref. No. APSFL/OLA/284-1/2018, Dated 02/03/2019**

S No	Item description	UoM	Quantity (A)	Unit Price (B)	Total Price (A*B)
1	Supply and installation of Optical Line Amplifier NCS 2006	Nos.	5		
1.1	NCS 2000 Transport Node Controller w/2x OTDR/OSC	Nos.	2		
1.2	SNTC-8X5XNBD NCS 2000 Transport Node Controller w/2x	Nos.	2		
1.3	NCS 2K/MSTP - R10.7 SW, TNCE, TSCE, TNCS/O - WSON CP	Nos.	2		
1.4	NCS 2006 Shelf Assembly	Nos.	1		
1.5	SNTC-8X5XNBD NCS 2006 Shelf Assembly	Nos.	1		
1.6	NCS 2006 LCD Display with Backup Memory	Nos.	1		
1.7	Empty slot Filler Panel	Nos.	4		
1.8	NCS 2006 Fan Tray	Nos.	1		
1.9	NCS 2006 1,500W AC Power Supply	Nos.	2		
1.10	NCS 2006 External Connections Unit	Nos.	1		
1.11	Fiber patch cord - LC to LC - 2m	Nos.	2		
1.12	15454 MSTP - Optical Amplifier - C-band - 24dB Gain	Nos.	2		
1.13	SNTC-8X5XNBD 15454 MSTP - Optical Amplifier - C-band	Nos.	2		
2	Supply, fixing of wall mount 48 port FDMS with required trays and splicing of necessary patch cords	Nos.	5		
3	EMS Licenses for OLA	Sets	5		
<b>Total in INR (1+2+3)</b>					
<b>Total (in Words)</b>					

### Note

- Supply to designated locations /central warehouse within AP as informed by APSFL.
- Unit Rate shall include all duties, levies, insurance, transport and other charges excluding Taxes.
- The Bidder offering the **Lowest Grand Total Cost (Exclusive of Taxes) for line items 1,2 and 3** will be considered for award of contract. Sub-line items under Sno1 shall be used for any future requirement if any.
- If there is a discrepancy between words and figures, the amount in words shall prevail.
- For additional procurement if any, the prices quoted for the mentioned items would be considered as discovered prices valid for one-year period.

**APSFL reserves the right to**

- Negotiate with the Bidder whose offer is the lowest (L1) for further reduction of prices.
- Ask other bidders to match the price of L1 to declare them as the shortlisted bidders and issue the order in case L1 defaults in performance of agreed terms and conditions.
- Modify, reduce or increase the quantity requirements to an extent of the tendered quantity
- If delivery performance of the Bidder is not as per the Schedule, then APSFL reserves the right to take action against them.
- APSFL reserves its right to withhold any amount for the deficiency in the service aspect of the ordered items supplied.

(Signature, name and designation of the authorized signatory)

(Name and seal of the firm)

## 8.11 Annexure X – Minimum Tech Specifications

### 1. Fibre Distribution Management System (FDMS) – 48 Fibres

SNo	Description
1	Supply, Assembly and Installation of 48F Rack Mounted FDMS
2	The unit shall have minimum 2U height with minimum 450mm depth & 485mm Width with Rigid Frame and Electro- Phoretic dip coated and then powder coated to Color RAL7035
3	<b>FDMS should include following</b>
4	a. Heavy duty Telescopic Sliding Rails of 2 Sets / Castor Wheels
5	b. Docket Holder on Top of the FDMS Frame “M” Type
6	c. Removable Sliding Tray for easy Maintenance of the Product with preinstalled wire brush/mesh on the rear side.
7	d. Minimum 2 Nos. of Fiber guide ensuring minimum bending dia. of not less than 70mm
8	e. The sliding tray should have Handles Chrome plate / Stainless Steel for easy access to the Cassettes
9	f. Splicing Cassettes with Maximum Capacity of 12 Splices on each Cassettes on Peripheral
10	g. Suitable Cable Clamps for Optical Cable Holding
11	h. Adaptors: 48 Nos. SC/APC from a CACT Approved Source.
12	i. Pigtails: 48 Nos. of SC/APC Pigtails from a CACT Approved Source of min. 1.5m length
13	j. Patch Chord Ports: Minimum of 04 patch chord ports to be supplied with suitable dia of PG Glands and 48 Nos. of SC-APC to SC-APC Patchchords of 10 Mtr Length from CACT Approved Source.
14	k. Splice Protection Sleeves: High Quality Individual Fiber Splice Protection Sleeves from a CACT Approved Source 60 Nos.

### 2. **Product IDs for Optical Line Amplifier NCS 2006:**

Description	Product ID
NCS 2000 Transport Node Controller w/2x OTDR/OSC	NCS2K-TNCS-O-K9=
SNTC-8X5XNBD NCS 2000 Transport Node Controller w/2x	CON-SNT- NCS2KTNO
NCS 2K/MSTP - R10.7 SW, TNCE, TSCE, TNCS/O - WSON CP	SF-NCS2K-R1070K9
NCS 2006 Shelf Assembly	NCS2006-SA=
SNTC-8X5XNBD NCS 2006 Shelf Assembly	CON-SNT-NCS2006A
NCS 2006 LCD Display with Backup Memory	NCS2006-LCD=
Empty slot Filler Panel	15454-BLANK=
NCS 2006 Fan Tray	NCS2006-FTA=
NCS 2006 1,500W AC Power Supply	NCS2006-AC=
NCS 2006 External Connections Unit	NCS2006-ECU=
Fiber patch cord - LC to LC - 2m	15454-LC-LC-2=
15454 MSTP - Optical Amplifier - C-band - 24dB Gain	15454-OPT-EDFA- 24=
SNTC-8X5XNBD 15454 MSTP - Optical Amplifier - C-band	CON-SNT-15454OPE