



**APSFL**  
Andhra Pradesh State FiberNet Ltd.

## **Request For Proposal**

**for**

## **Supply of Universal Pole Accessories and Joint Enclosures**

**Ref. No. APSFL/Spares Requirements/342/2019/02, Dated 06/11/2019**

Andhra Pradesh State FiberNet Limited

NTR Administrative Block, 3rd Floor, Pandit Nehru Bus Station,

Vijayawada - 520013

Web address: [www.apsfl.in](http://www.apsfl.in)

Email address: [apsfl@ap.gov.in](mailto:apsfl@ap.gov.in)

## **Disclaimer**

The information contained in this Tender document or subsequently provided to Applicants, whether verbally or in documentary or any other form by or on behalf of the APSFL or any of its employees or advisers, is provided to Applicants on the terms and conditions set out in this TENDER and such other terms and conditions subject to which such information is provided.

This TENDER is not an agreement and is neither an offer nor invitation by the APSFL to the prospective Applicants or any other person. The purpose of this TENDER is to provide interested parties with information that may be useful to them in the preparation of their Proposals pursuant to this TENDER. This TENDER includes statements, which reflect various assumptions and assessments arrived at by APSFL. Such assumptions, assessments and statements do not purport to contain all the information that each Applicant may require. This TENDER may not be appropriate for all persons, and it is not possible for APSFL, its employees or advisers to consider the objectives, technical expertise and particular needs of each party who reads or uses this TENDER. The assumptions, assessments, statements and information contained in this TENDER, may not be complete, accurate, adequate or correct. Each Applicant should, therefore, conduct its own investigations and analysis and should check the accuracy, adequacy, correctness, reliability and completeness of the assumptions, assessments and information contained in this TENDER and obtain independent advice from appropriate sources.

Information provided in this TENDER to the Applicants is on a wide range of matters, some of which depends upon interpretation of law. The information given is not an exhaustive account of statutory requirements and should not be regarded as a complete or authoritative statement of law. APSFL accepts no responsibility for the accuracy or otherwise for any interpretation of the law.

APSFL, its employees and advisers make no representation or warranty and shall have no liability to any person including any Applicant under any law, statute, rules or regulations or tort, principles of restitution or unjust enrichment or otherwise for any loss, damages, cost or expense which may arise from or be incurred or suffered on account of anything contained in this TENDER or otherwise, including the accuracy, adequacy, correctness, reliability or completeness of the TENDER and any assessment, assumption, statement or information contained therein or deemed to form part of this TENDER or arising in any way in this Selection Process.

APSFL also accepts no liability of any nature whether resulting from negligence or otherwise, howsoever caused, arising from reliance of any Applicant upon the statements contained in this TENDER. APSFL may in its absolute discretion, but without being under any obligation to do so, update, amend or supplement the information, assessment or assumption contained in this TENDER.

Issuance of this TENDER does not imply that the APSFL is bound to select an Applicant or to appoint the Selected Applicant, as the case may be, for the TENDER, APSFL reserves the right to reject all or any of the Proposals without assigning any reasons whatsoever.

The applicant shall bear all its costs associated with or relating to the preparation and submission of its Proposal including but not limited to preparation, copying, postage, delivery fees, expenses associated with any demonstrations which may be required by the APSFL or any other costs incurred in connection with or relating to its Proposal. All such costs and expenses will remain with the Applicant and APSFL shall not be liable in any manner whatsoever for the same or for any other

*Supply of necessary Pole accessories along with splicing joint enclosures*

costs or other expenses incurred by an Applicant in preparation or submission of the Proposal, regardless of the conduct or outcome of the selection process

## **Definitions**

- **“Authority”** refers to MD/Directors of APSFL or its nominated representatives
- **“Authorized Representative”** shall mean any person authorized by either of the parties.
- **“Bidder/Supplier”** means any firm or group of firms (called consortium) offering the solution(s), service(s) and /or materials as required in the TENDER. The word Bidder/ Supplier when used in the pre-award period shall be synonymous with parties bidding for this TENDER, and when used after award of the Contract shall mean the successful party with whom APSFL signs the agreement for rendering of services for implementation of this project.
- **“Law”** shall mean any Act, notification, bye law, rules and regulations, directive, ordinance, order or instruction having the force of law enacted or issued by the Central Government and/ or Andhra Pradesh or regulatory authority or political subdivision of government agency.
- **“LoA”** means Letter of Acceptance, which shall constitute the intention of the department to place the Purchase Order with the successful bidder.
- **“Party”** means APSFL or Bidder, individually and **“Parties”** mean APSFL and Bidder, collectively.
- **“Proposal / Bid”** means the Pre-Qualification and Technical Proposals submitted along with the subsequent clarifications and undertakings, if any;
- **“Request for Proposal (TENDER)”** means this document and its annexure etc., seeking a set of solution(s), services(s), materials and/or any combination of them.
- **“Requirements”** shall mean and include schedules, details, description, statement of technical data, performance characteristics and standards (Indian & International) as specified in TENDER.

## 1. Inviting Authority

Andhra Pradesh State FiberNet Limited (APSFL) invites sealed bids from the prospective bidders for supply of necessary Pole accessories along with splicing joint enclosures sufficient for 100 Kms of 24F ADSS CABLE with span length of 65m with wind speed of 100 kmph. The bidders shall propose all the components as per the technical specifications mentioned in this TENDER and selected bidder(s) should support APSFL in providing reliable service delivery.

### 1.1 Key Events and Dates

Sl. No.	Description	Details
1.	Name of the Authority	Andhra Pradesh State FiberNet Limited
2.	Name of the Assignment	Request For Proposal for Supply of Universal Pole Accessories and Joint Enclosures
3.	TENDER Number	<b>APSFL/ Spares requirements/342/2019/02, Dt: 06.11.2019</b>
4.	TENDER Publishing Date	<b>06.11.2019</b>
5.	Last date and time for submission of proposal (Proposal Due Date)	<b>on or before 13.11.2019 - 3:00 PM</b> The proposal is to be submitted to APSFL corporate Office, Vijayawada.
6.	Date and time of opening of pre-qualification cum technical bids on e-procurement platform	<b>13. 11.2019 at 4:00 PM</b> Andhra Pradesh State FiberNet Limited NTR Administrative Block, 3rd Floor, Pandit Nehru Bus Station, NH -65, Vijayawada - 520013 Web address: <a href="http://www.apsfl.in">www.apsfl.in</a> Email address: <a href="mailto:apsfl@ap.gov.in">apsfl@ap.gov.in</a>
7.	Date and time of opening of financial bid	Shall intimate technically qualified agencies at a later date
8.	Bid Processing Fee (Non-refundable)	<b>INR 10,000 (INR Ten thousand Only)</b> in the form of Demand Draft issued by one of the Nationalized / Scheduled Banks in India drawn in favour of <b>Andhra Pradesh State FiberNet Ltd'</b> , payable at Vijayawada.  Original DD must be submitted in APSFL office at Vijayawada before Proposal Due Date.
9.	Bid Security / EMD (Refundable)	<b>INR 1,50,000 (Rupees One Lakh Fifty thousand Only)</b> in the form of Bank Guarantee issued by one of the Nationalized / Scheduled Commercial Banks in India drawn in favour of Andhra Pradesh State FiberNet Ltd, payable at Vijayawada.  Original BG must be submitted in APSFL office at Vijayawada before proposal due date. Bid Security / EMD should be valid for a period of 180 (One Hundred & Eighty) days from Proposal Due Date. The Bid Security / EMD will be refunded to unsuccessful bidders.

10.	For any enquiries and clarifications, please contact:	Executive Director –Operations, Andhra Pradesh State FiberNet Limited NTR Administrative Block, 3rd Floor, Pandit Nehru Bus Station, Vijayawada - 520013 Web address: <a href="http://www.apsfl.in">www.apsfl.in</a> Email: <a href="mailto:edo1.apsfl@ap.gov.in">edo1.apsfl@ap.gov.in</a>
11.	Validity of the Proposal	Bidder proposals shall remain valid for a period of 180 days from the Proposal due date.

## 1.2 Bid Submission:

All bidders should submit documents in hard copy Original DD towards the bid processing the fee & Original BG towards EMD in APSFL office at Vijayawada before proposal due date.

Details of Bank for EMD:

Name of Beneficiary	Andhra Pradesh State Fibernet Limited
Name of Bank	Andhra Bank
Bank address	Andhra Bank, Main Branch, RR Apparao street, Vijayawada, Andhra Pradesh
Bank Account No	100611100002032
IFSC CODE	ANDB0000606
MICR CODE	520011025
BRANCH CODE	000606

## 2. Scope of Work

APSFL has established state-wide high speed optical fiber network infrastructure covering approximately 23,000 kms route across the 13 districts of Andhra Pradesh through 2471 PoPs and 12 DHQs being operated and controlled from Network Operations Centre (NOC) setup in Vishakhapatnam. APSFL is providing triple play services (voice, iptv and data) on top of this network through GPON ONTs at last mile.

Through this Tender, APSFL is planning to procure necessary Pole accessories along with splicing joint enclosure for 100 Kms of 24F ADSS CABLE with span length of 65m with wind speed of 100 kmph for restoration to provide uninterrupted services to End users.

The Equipment procured through this Tender, should seamlessly provide the specified technical specifications to provide services to APSFL. The successful bidder shall ensure to supply the necessary Pole accessories along with splicing joint enclosure sufficient for 100 Kms of 24F ADSS CABLE with span length of 65m with wind speed of 100 kmph as per the specifications given below at Central warehouse / Designated Location in Andhra Pradesh within **two weeks** from the date of Purchase Order.

## 2. Pre-Qualification Criteria

The prospective bidders must satisfy the following eligibility criteria for submission of their bids and provide supporting documents as proof of eligibility.

S. No.	Prequalification Criteria	Documentary Proof to be submitted
1.	The bidder members should be a Company registered in India under the Indian Companies Act 1956/2013 or a Registered Partnership Firm or a Sole Proprietary Firm or LLP.	Bidder should produce the copy of the Certificate of Incorporation
2.	The Sole Bidder should have average annual turnover (TO) of minimum six crores in Indian Rupees from activities relating to Telecom supply or Services for last 3 audited financial years	Copies of the Audited Balance sheets and Profit and Loss Accounts for the last 3 audited financial years
3.	The bidder should have executed One work order in supplying networking/telecom equipment for a min value of INR 50 Lakhs each in last 3 years.	<ul style="list-style-type: none"> <li>• Copy of Purchase Order / Work Order / Contract / Agreement</li> <li>• Completion/Ongoing certificate issued and signed by Client</li> </ul>
4.	The Bidder should have valid GST registration in India	Certified copy of valid GST registration certificates issued by competent authority in India.
5.	The Bidder should not have been blacklisted by any Govt or PSU in India as on the date of bid submission	Self-declaration by the bidder duly signed by the authorized signatory
6.	The bidder shall submit MAF from the Original Equipment Manufacturer	MAF should be submitted as per the Annexure given in this tender.

### 3. Delivery & Documents

Delivery of Equipment shall be made by the selected vendor strictly in accordance with the specifications of the tender document or in case of deviations, the specifications approved and accepted by APSFL. Corresponding documentation shall be submitted to APSFL along with delivery.

Delivery to the designated locations of APSFL is responsibility of the selected bidder.

### 4. Execution of Order

The Successful Bidder should nominate and intimate APSFL, an Account Manager for Single Point of Contact (SPOC), who should be responsible for effective delivery complying with all the terms and conditions. The Successful Bidder should ensure that the Account Manager fully familiarizes with the Tender Conditions, Scope of Work and deliverables.

### 5. Payment Terms

- 90% payment within 30 days after successful delivery of the equipment, submission of invoice, delivery challan and all related documents duly certified by APSFL Authority and completed in all aspect.
- 10% payment of work order within 60 from the release of first Payment.

## 6. Annexures

### I. Checklist

Sl. No.	Documents	Compliance (Yes/No)
1.	Cover Letter	
2.	Bidder Profile as per given format	
3.	Financial Information as per given format	
4.	Declaration of acceptance of TENDER terms and conditions	
5.	Declaration of clean track record / No Blacklisting	
6.	EMD as per the given format	
7.	Price Bid as per given format	
8.	Registration certificate of the company.	
9.	Copy of Purchase Orders/client certificate should be submitted	
10.	In the case of authorized distributor/dealer, a Letter of Authorization from the OEM/manufacturers or the dealer certificate	
11.	In the case of OEM, the documentary proof for manufacturing the products.	
12.	Copies of the Audited Balance sheets and Profit and Loss Accounts for the last 3 financial years	
13.	Certified copy of valid GST registration certificates issued by competent authority in India. In case of consortium, this is applicable for all Indian members.	
14.	The bidder shall submit all the technical leaflets / technical literature / product certifications etc. to confirm the technical compliance.	
15.	The OEM should submit the compliance confirmation for each parameter in their letterhead.	
16.	Manufacturer Authorization Form for 24F Adss cable	
17.	If there is any deviation, the deviation with justification should be spelt out.	
18.	Index of furnished documents for the Prequalification criteria	

### II. Annexure I – Cover Letter

(To be submitted by Bidder on Original Letterhead)

To  
The Managing Director,  
Andhra Pradesh State FiberNet Limited,  
3rd Floor, NTR Administrative Block,  
Pandit Nehru Bus Station, NH – 65, Vijayawada – 520013

[Date]

**Subject: RFP \_\_\_\_\_**

**Ref: \_\_\_\_\_**

Dear Sir,

With reference to your TENDER Document dated ..... I/We, having examined all relevant documents and understood their contents, hereby submit our Proposal.



*Supply of necessary Pole accessories along with splicing joint enclosures*

1. All information provided in the Proposal and in the Appendices, is true and correct and all documents accompanying such Proposal are true copies of their respective originals.
2. I/We shall make available to the Authority any additional information it may deem necessary or require for supplementing or authenticating the Proposal.
3. I/We acknowledge the right of the Authority to reject our Proposal without assigning any reason or otherwise and hereby waive our right to challenge the same on any account whatsoever.
4. I/We to the best of our knowledge certify that in the last three years, we or any of our Associates have neither failed to perform on any contract, as evidenced by imposition of a penalty by an arbitral or judicial authority or a judicial pronouncement or arbitration award against the Bidder, nor been expelled from any project or contract by any public authority nor have had any contract terminated by any public authority for breach on our part.
5. I/We understand that you may cancel the Selection Process at any time and that you are neither bound to accept any Proposal that you may receive nor to select the vendor, without incurring any liability to the Bidders
6. I/We to the best of our knowledge certify that, we or any of our Associates have not been convicted by a Court of Law or indicted or adverse orders passed by a regulatory authority which would cast a doubt on our ability to undertake the Project or which relates to a grave offence that outrages the moral sense of the community.
7. I/We to the best of our knowledge further, we have not been charge-sheeted by any agency of the Government or convicted by a Court of Law for any offence committed by us or by any of our Associates.
8. I/We agree and understand that the Proposal is subject to the provisions of the TENDER document. In no case, shall I/We have any claim or right of whatsoever nature if our Proposal is not opened or rejected.
9. I/We agree to keep this offer valid for 180 days from the Proposal Due Date specified in the TENDER.
10. I/We agree and undertake to abide by all the terms and conditions of the TENDER Document. In witness thereof, I/We submit this Proposal under and in accordance with the terms of the TENDER Document.

Yours faithfully,

(Signature, name and designation of the authorized signatory)

(Name and seal of the firm)

**III. Annexure II – Bidder Profile**

(To be submitted by Bidder/consortium members on original letterhead)

#	Particulars	Details
1.	Name of the Company	
2.	Year of incorporation	
3.	Nature of the Company (Registered Company)	
4.	<b>Registered Office Address</b>	
	Office Telephone Number	
	Fax Number	
5.	<b>Contact Person</b>	
	Name	
	Telephone Number	
	Email Address	
6.	<b>Local presence at Andhra Pradesh</b>	
	Office Address	
	Office Telephone Number	
	Fax Number	
7.	<b>Contact Person (in Andhra Pradesh)</b>	
	Name	
	Telephone Number	
	Email Address	
8.	<b>Registration Details</b>	
	Permanent Account Number (PAN)	
	GST Number	
9.	Banker's Name, Address and Account Number	

#### IV. Annexure III - Financial Information

(To be submitted by Bidder on original letterhead)

##### Annual Turnover of the Bidder(s)

Criteria	Sub Criteria	FY	Total Financials
Financial Capability	Annual Turnover (in INR)	FY 2016-17	
		FY 2017-18	
		FY 2018-19	

##### Documentary Proof Required:

- Statutory auditor's/Practising Chartered Accountant's certificate clearly specifying the Turnover for the specified years.
- Audited/Provisional Balance Sheets and Profit & Loss statements for the last 3 financial years

#### V. Annexure IV- Declaration of Acceptance of TENDER Terms & Conditions

(To be submitted by Bidder on original letterhead)

To, [Date]  
The Managing Director,  
Andhra Pradesh State FiberNet Limited,  
3rd Floor, NTR Administrative Block,  
Pandit Nehru Bus Station, NH – 65, Vijayawada – 520013

**Subject: RFP \_\_\_\_\_**

**Ref: \_\_\_\_\_**

Sir,

It is to certify that the TENDER document – TENDER No..... dated..... is carefully read & understood and all the sections and clauses are COMPLIED UNCONDITIONALLY AND UNEQUIVOCALLY. There is no deviation from the terms & conditions of the TENDER. We also hereby confirm that the solution proposed by us will meet the project requirements.

Yours faithfully,

(Signature, name and designation of the authorized signatory)

(Name and seal of the firm)

*Supply of necessary Pole accessories along with splicing joint enclosures*

**VI. Annexure V - Declaration of Clean Track Record/ No Blacklisting**

(To be submitted by Bidder on original letterhead)

To,

[Date]

The Managing Director,

Andhra Pradesh State FiberNet Limited,

3rd Floor, NTR Administrative Block,

Pandit Nehru Bus Station, NH – 65, Vijayawada – 520013.

**Subject: RFP \_\_\_\_\_**

**Ref: \_\_\_\_\_**

Sir,

I/We hereby declare that my company has not been debarred / black listed as on Bid submission date by any State Government, Central Government, Central & State Govt. Undertakings / Organizations and by any other Quasi Government bodies / Organizations, and any other major Enterprise / Organizations in India for non-satisfactory past performance, corrupt, fraudulent or any other unethical business practices.

Yours faithfully,

(Signature, name and designation of the authorized signatory)

(Name and seal of the firm)

**VII. Annexure VI- Manufacturer's Authorization Form (MAF)**

(To be submitted in Manufacturer's letterhead)

To  
The Managing Director,  
Andhra Pradesh State FiberNet Limited,  
3rd Floor, NTR Administrative Block,  
Pandit Nehru Bus Station, NH – 65, Vijayawada – 520013

Sir,

We hereby authorize M/s \_\_\_\_\_ to undertake to submit a Bid, and subsequently negotiate & sign the contract with APSFL for the Tender No: \_\_\_\_\_ for product manufactured by us.

We also undertake to provide timely supplies as per terms of tender and as agreed mutually and also to provide a trouble free and continuous support either directly or through our authorized distributors/dealers under our supervision during the said support period. We will provide the necessary support in the event of up gradation of any of the software is necessitated while providing the support will arrange for complete replacement of the item(s) with an equivalent / higher version.

**In case of violation of any of the conditions above, I/We understand that I/We are liable to be blacklisted by APSFL for a period of three years.**

(Signature of authorized Personnel)

**Note:** Competent authority of the Manufacturer should issue the letter of authority individually for each bidder separately.

### VIII. Annexure VII – Price Bid Forms

(To be submitted by Bidder on original letterhead)

To

Date:

The Managing Director,  
Andhra Pradesh State FiberNet Limited,  
3rd Floor, NTR Administrative Block,  
Pandit Nehru Bus Station,  
NH – 65, Vijayawada – 520013

**Subject: TENDER for Procurement of necessary Pole accessories along with splicing joint enclosure sufficient for 100 Kms of 24F ADSS CABLE with span length of 65m with wind speed of 100 kmph for AP Fiber Grid Network**

SNo	Description	Cost in INR (Per Annum)
1.	Necessary Pole accessories ( Suspension clamps , tension clamps, locks etc) sufficient for 100Kms of 24F ADSS cable	
2.	Necessary Joint enclosures sufficient for 100Kms of 24F ADSS cable	
Total in INR (words)		

#### Note

- Unit Rate shall include all duties, levies, insurance, transport and other charges excluding Taxes.
- **The Bidders offering the Lowest Cost (Exclusive of Taxes) will be considered for award of Purchase Order.**
- If there is a discrepancy between words and figures, the amount in words shall prevail.

#### APSFL reserves the right to

1. Negotiate with the Bidder whose offer is the lowest (L1) for further reduction of prices.
2. Ask other bidders to match the price of L1 to declare them as the shortlisted bidders and issue the order in case L1 defaults.
3. Modify, reduce or increase the quantity requirements to an extent of the tendered quantity
4. APSFL may place the repeat order based on the requirement.
5. APSFL reserves its right to withhold any amount for the deficiency in the service aspect of the ordered items supplied.

(Signature, name and designation of the authorized signatory)

**Annexure VIII -EMD Format**

(To be executed in Rs.100/- Stamp Paper)

To,  
The Managing Director,  
Andhra Pradesh State FiberNet Limited,  
3rd Floor, NTR Administrative Block,  
Pandit Nehru Bus Station,  
NH – 65, Vijayawada – 520013

Bank Guarantee No:  
Amount of Guarantee:  
Guarantee covers from:  
Last date for lodgment of claim:

This Guarantee executed by \_\_\_\_\_ (Banker's Name & Address) having our Head Office at \_\_\_\_\_ (address) (hereinafter referred to as “Bank”) in favour of Andhra Pradesh State FiberNet Limited NTR Administrative Block, 3rd Floor, Pandit Nehru Bus Station, NH -65, Vijayawada – 520013 India (hereinafter referred to as “Beneficiary”) for an amount not exceeding Rs. \_\_\_\_\_/- (Rupees \_\_\_\_\_ Only) as per the request of M/s. \_\_\_\_\_ having its office address at \_\_\_\_\_ (hereinafter referred to as “Bidder”) against RFP reference \_\_\_\_\_ dated \_\_\_/\_\_\_/\_\_\_ of M/s. Andhra Pradesh State FiberNet Limited (APSFL). This guarantee is issued subject to the condition that the liability of the Bank under this guarantee is limited to a maximum of Rs. \_\_\_\_\_ /- (Rupees \_\_\_\_\_ Only) and the guarantee shall remain in full force up to \_\_\_\_\_ (date) and cannot be invoked otherwise by a written demand or claim by the beneficiary under the Guarantee served on the Bank before \_\_\_\_\_ (date).

ANDWHEREAS it has been stipulated by you in the said ORDER that the Supplier shall furnish you with a Bank Guarantee by a Scheduled/Nationalized Bank for the sum specified therein as EMD towards bid submission.

ANDWHEREAS we have agreed to give the Bidder a Guarantee.

THEREFORE, we (Bankers address), hereby affirm that we are Guarantors and responsible to you on behalf of the Bidder for Rs. \_\_\_\_\_/- (Rupees \_\_\_\_\_ Only) and we undertake to pay you, upon your first written demand without any demur, cavil or argument, any sum or sums within the limit of Rs. \_\_\_\_\_/- (Rupees \_\_\_\_\_ Only) as aforesaid, without your needing to prove or show grounds or reasons for your demand or the sum specified therein. We will pay the guaranteed amount notwithstanding any objection or dispute whatsoever raised by the Bidder.

This Guarantee is valid until \_\_\_\_\_.

Place:

Date:                      Signature and seal of Guarantors (Bank)

**Annexure IX – Minimum Tech Specifications**

**Universal Pole Accessories**

**Tension Pole Assembly**– Should Contain following

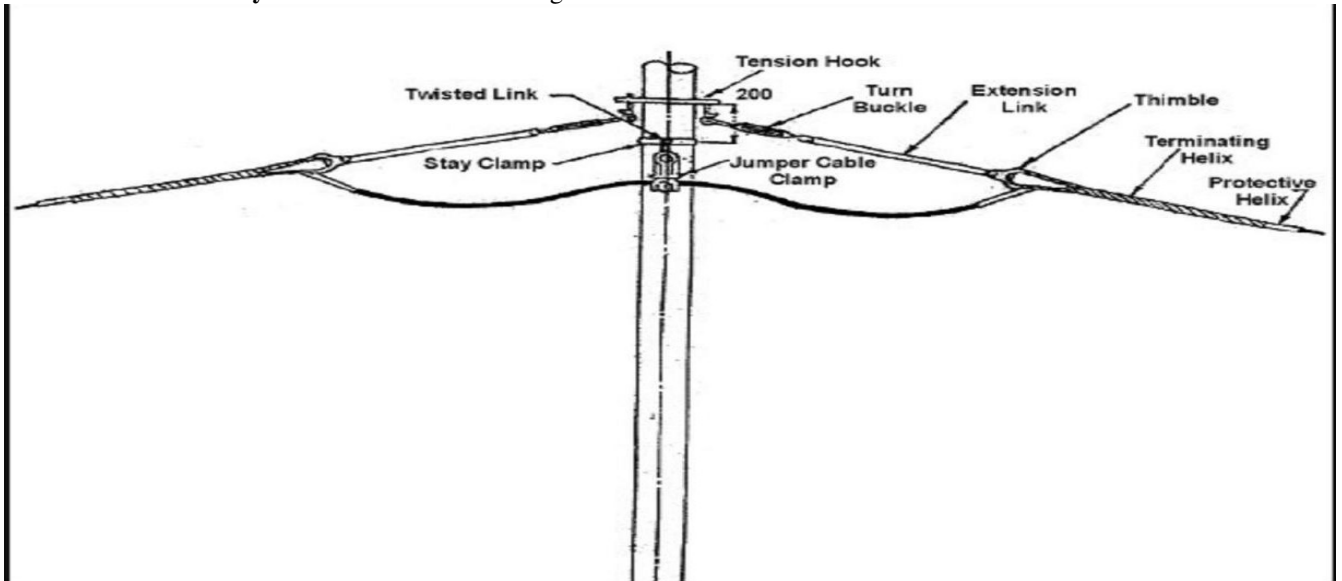

- Twisted Link
- Stay Clamp
- Tension Hook
- Turn Buckle
- Extension Link
- Thimble
- Terminating Helix
- Jumper Cable Clamp
- Protective Helix

**Tension Hook:**

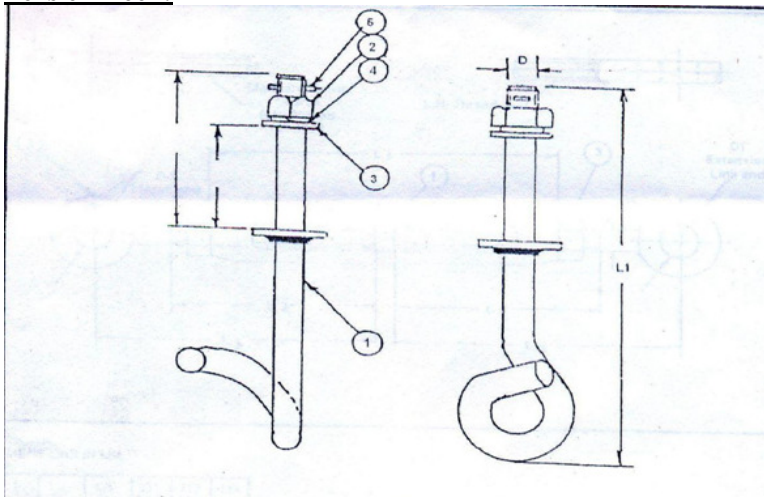

Dimensions in MM:

L1	L2	L3	D
177	75	50	12

Note: - Tolerance shall be as per IS:2102  
(Detail as per GR, Unless UNTILL Specified)

To be used here C-Bracket is available on pole for fitment of Tension Hook.



Supply of necessary Pole accessories along with splicing joint enclosures

HOT DIP GAVANISED as per IS.2629

	Description	Material	Ref Spec	Qty
1	Body	Alloy Steel Galvanised	IS:2004	
2	Nut	Mild Steel Galvanised	IS:1363	
3	Plain Washer	Mild Steel Galvanised	IS:2016	
4	Spring Washer	Spring Steel Galvanised	IS:3063	
5	Spilt Pin	Stainless Steel	IS:549	

TENSION HOOK	
NOT TO SCALE	Unit-MM

**TURN BUCKEL:**

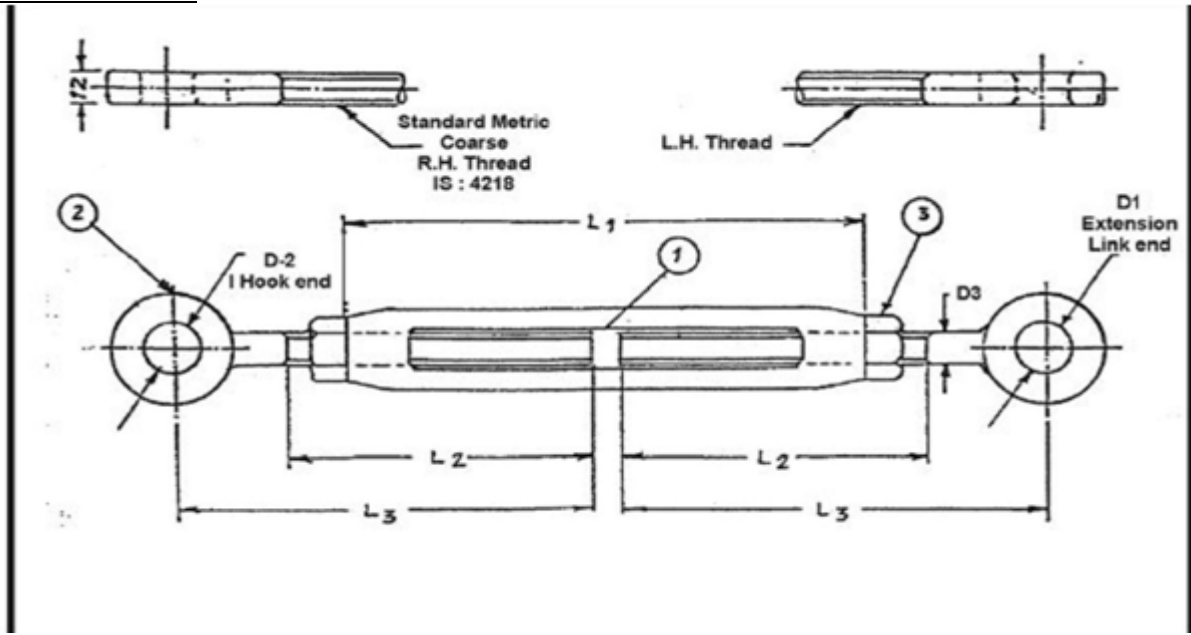

Dimensions in MM:

L1	L2	L3	D1	D2	D3
170	100	140	18	18	12

Note: - Tolerance shall be as per IS:2102  
 (Detail as per GR, Unless UNTILL Specified)  
 MIN Length : 290 MM  
 MAX Length : 400 MM  
 Range of ADL : 110 MM  
 HOT DIP GAVANISED as per IS.2629

	Description	Material	Ref Spec	Qty
1	Body	Mild Steel Forged Glav	IS:2004	

Supply of necessary Pole accessories along with splicing joint enclosures

2	Nut Bolt	Mild Steel Forged Glav	IS:2062	
3	Nut	Mild Steel	IS:1363	

**Extension Link:**

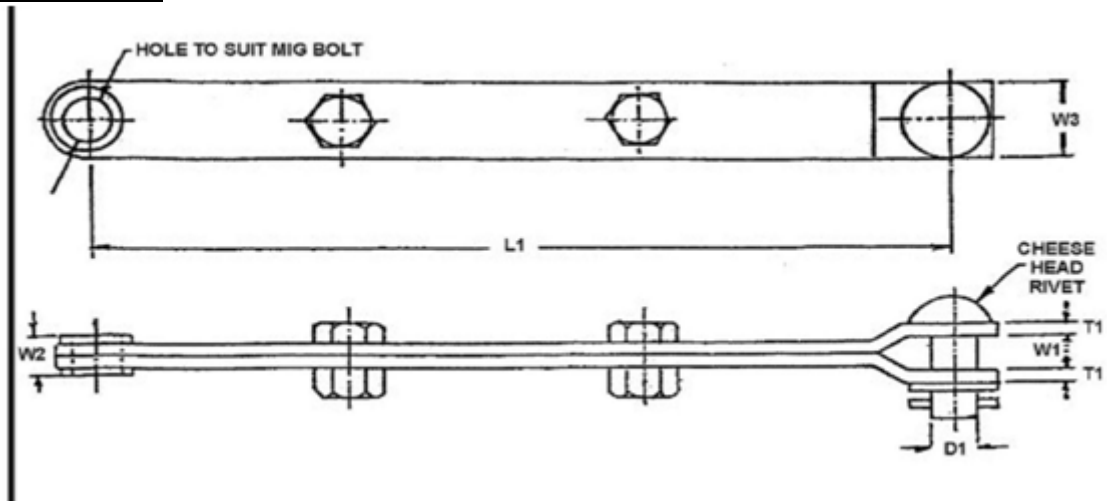

Dimensions in MM:

L1	T1	W1	W2	W3	D1
465	5	14	16	30	16

Note: - Tolerance shall be as per IS:2102  
(Detail as per GR, Unless UNTILL Specified)  
HOT DIP GAVANISED as per IS.2629

	Description	Material	Ref Spec	Qty
1	Strap	Mild Steel Galvanised	IS:2067	
2	Rivet & Washer	Mild Steel Galvanised	IS:2016	
3	Split Pin	Stainless Steel	IS:549	
4	Bolt & Nut M16	Mild Steel Galvanised	IS:1363	

**Clevis Thimble:**

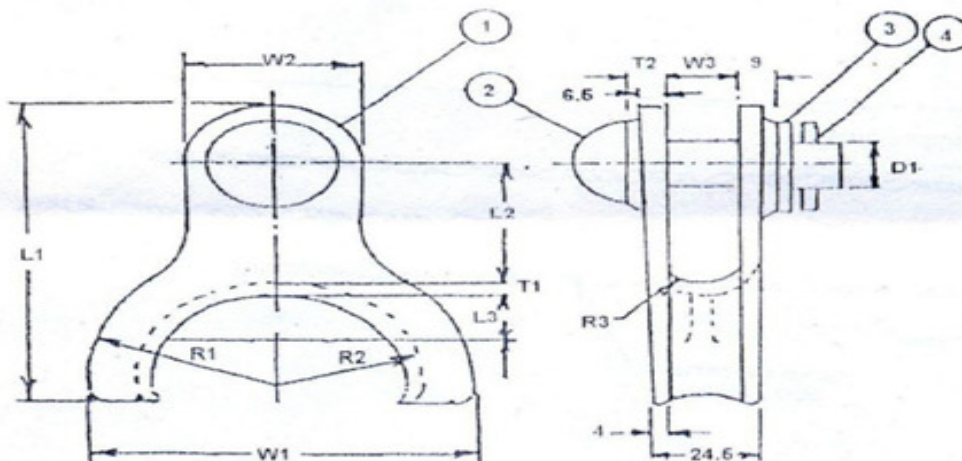

*Supply of necessary Pole accessories along with splicing joint enclosures*

Dimensions in MM:

L1	L2	L3	T1	T2	R1	R2	R3	W1	W2	W3	D1
102	42	15	4	9	23	15	8	92	40	18	16

Note: - Tolerance shall be as per IS:2102

(Detail as per GR, Unless UNTILL Specified)

FEROUS PARTS ARE HOT DIP GAVANISED as per IS.2629

	Description	Material	Ref Spec	Qty
1	Clamp	Aluminium Alloy GDC	IS:617	
2	Rivet M16 x 45	Galv Steel	IS:2016	
3	Washer	Galv Steel	IS:2016	
4	Split Pin	Stainless Steel	IS:549	

**CLEVIS THIMBLE**

NOT TO SCALE

Unit-MM

**Protective Helix (T):**

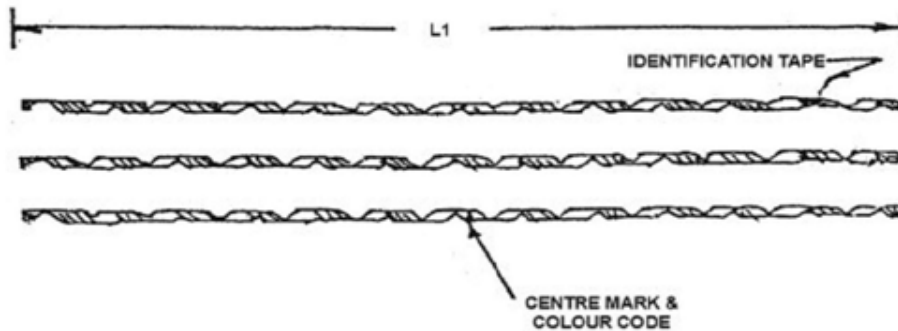

For Example

Dimensions (For Cable Size, D – 14.4 MM)

- i. DIA OF EACH WIRE –  $3.2 \pm 0.1$
- ii. NO OF SETS – 3
- iii. NO OF WIRE PER SET – 5
- iv. LENGTH OF HELIX – 1000

Dimension details for other cable size shall be indicated by the Manufacturer including the pitch of HELIX.

Note: Ends of RODS shall be deburred Tolerance shall be as per IS:2102

(Detail as per GR, Unless UNTILL Specified)

	Description	Material	Ref Spec	Qty
1	Protective Helx	Aluminium Alloy 6061		

**Terminating Helix:**

Supply of necessary Pole accessories along with splicing joint enclosures

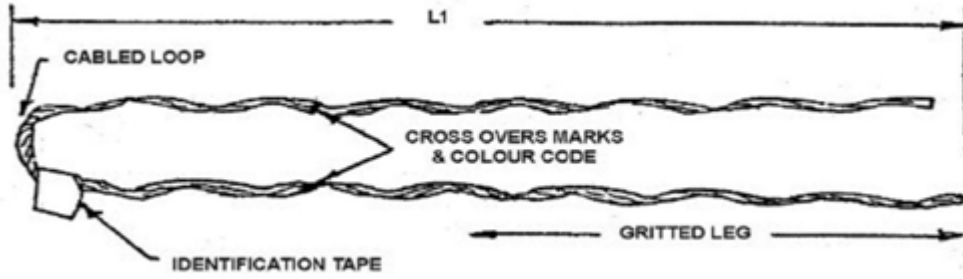

Dimensions for Example

L1	T1
1000	2.2±0.1

D is DIA of each Wire ROD  
No. of Wires used – 5

Note: Tolerance shall be as per IS:2102

(Detail as per GR, Unless UNTILL Specified)  
Dimension details for differe Cable size to be decided AP type Test Approval

For Example Cable Size  
Ends of RODA shall be Debur Length of Terminating Helx 1000MM  
Terminating Helix to be used with Thimble C DIA – 14.4 MM

	Description	Material	Ref Spec	Qty
1	DEADEHD GRIP	Aluminised Steel		

**Jumper Cable Clamp:**

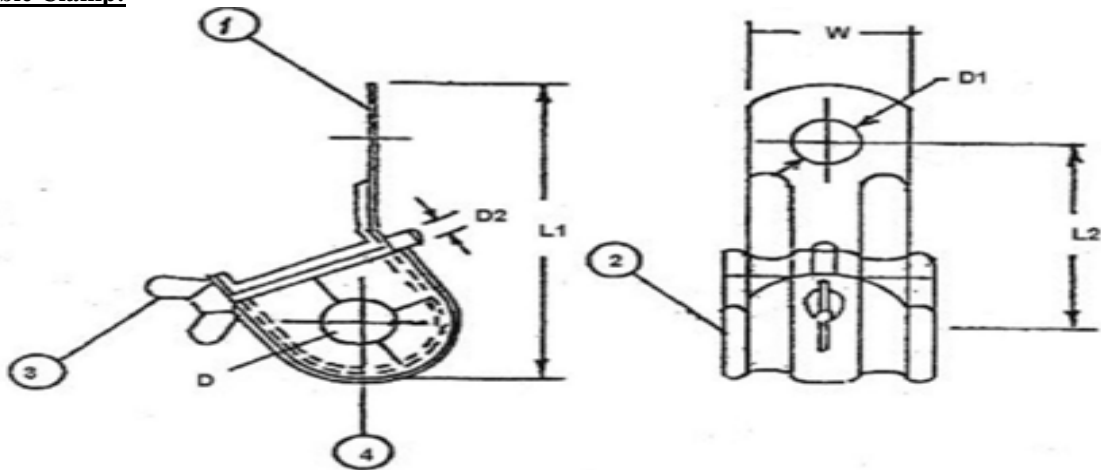

Dimensions in MM:

L1	L2	D1	D2	W
105	65	17.5	5-6	35

Dimensions in MM of Insert PAD:

L	INNER DIA	OUTER DIA
40	15	30

Note: Tolerance shall be as per IS:2102

*Supply of necessary Pole accessories along with splicing joint enclosures*

(Detail as per GR, Unless UNTILL Specified)

Insert in TOW HALVES D to suit Cable DIA Ferrous Parts are HOT DIP GALVASIED as per IS:2629

	Description	Material	Ref Spec	Qty
1	STRAP	Mild Steel GALY	IS:2062	
2	Insert	Polychloradprene Compounded		
3	Wing Bolt	Mild Steel GALY	IS:2062	

**Pole Mounted Stat Clamp**

**(Tubular):**

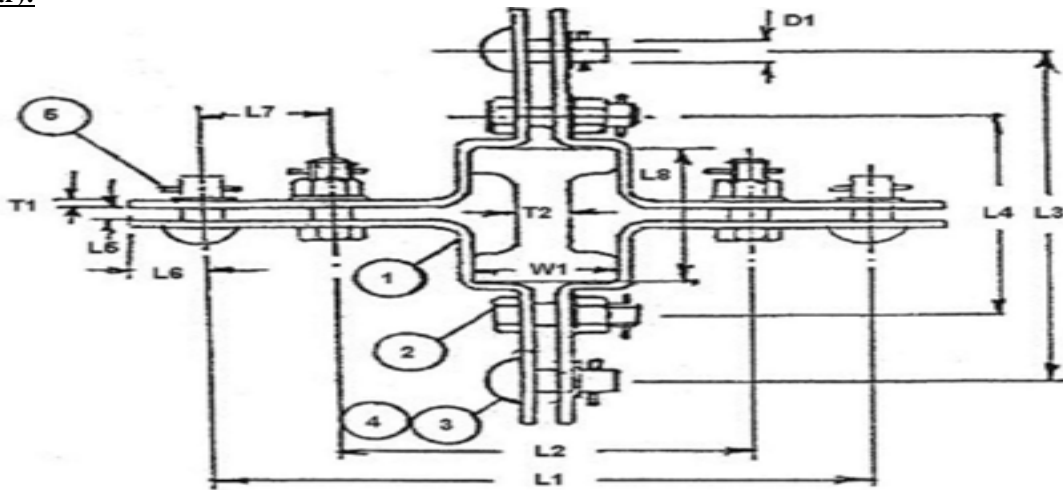

Dimensions in MM:

Pole Mouted Stay Clamp Tubular

L1	L2	D1	D2	T1	W
210	20	150	16	5	30

Note: - Tolerance shall be as per IS:2102

(Detail as per GR, Unless UNTILL Specified)

HOT DIP GAVANISED as per IS.2629

	Description	Material	Ref Spec	Qty
1	Clamp	Mild Steel Galvanised	IS:2062	
2	Bolt & Nut M16	Mild Steel Galvanised	IS:1363	
3	Rivet 16	Mild Steel Galvanised	IS:2016	
4	Washer	Mild Steel Galvanised	IS:2016	
5	Split Pin	Stainless Steel	IS:549	

**Pole Mounted Stay Clamp (Rail):**

Supply of necessary Pole accessories along with splicing joint enclosures

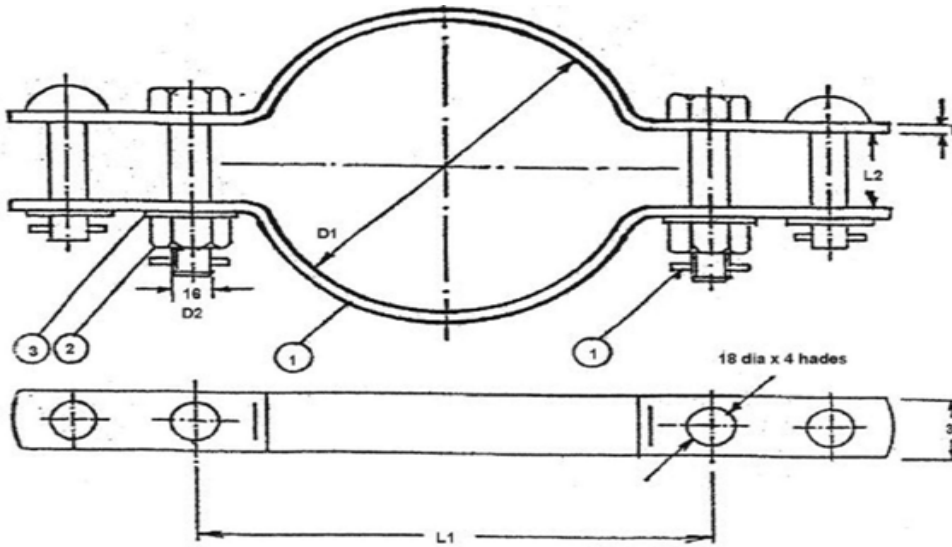

Pole Mounted Stay Clamp (Rail)

L1	L2	L3	L4	L5	L6	L7	L8	T1	T2	D1	W1
270	170	251	151	20	32	50	120	5	20	16	60

Note: - Tolerance shall be as per IS:2102  
 (Detail as per GR, Unless UNTILL Specified)  
 HOT DIP GAVANISED as per IS.2629

	Description	Material	Ref Spec	Qty
1	Clamp	Mild Steel Galvanised	IS:2062	
2	Bolt & Nut M16	Mild Steel Galvanised	IS:1363	
3	Rivet 16	Mild Steel Galvanised	IS:2016	
4	Washer	Mild Steel Galvanised	IS:2016	
5	Split Pin	Stainless Steel	IS:549	

**Suspension Pole Assembly:** Should Contain Following

Supply of necessary Pole accessories along with splicing joint enclosures

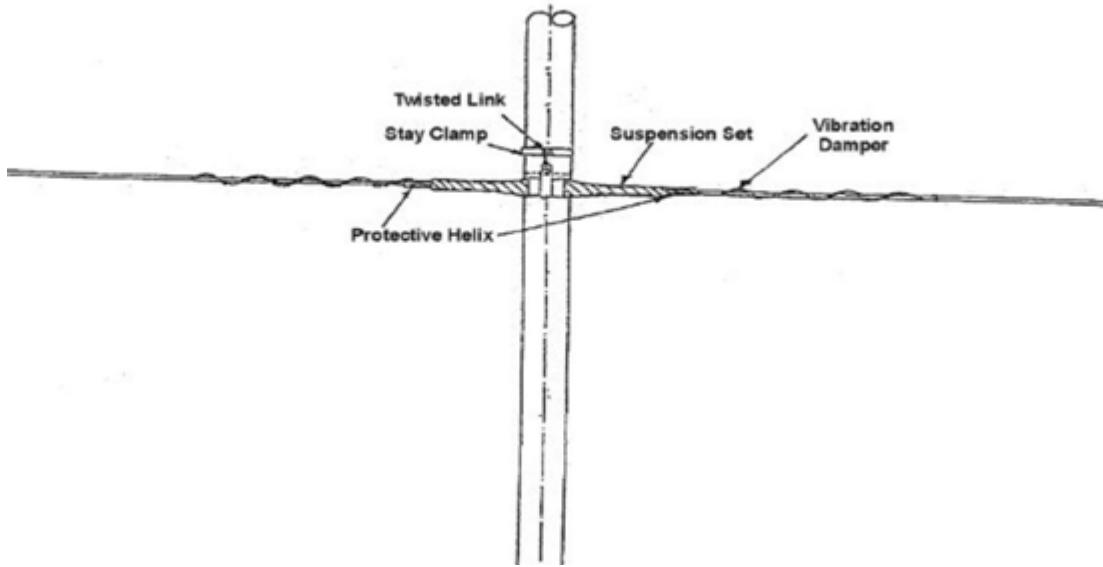

- Twisted Link
- Stay Clamp
- Protective Helix
- Suspension Set
- Vibration Damper

Suspension Pole Assembly	
NOT TO SCALE	Unit – MM

**Twisted Eye Link:**

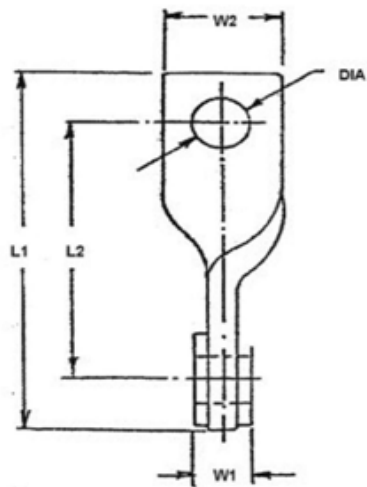

Dimensions in MM:

L1	L2	W1	W2	DIA
138	100	27	38	18

Note: - Tolerance shall be as per IS:2102  
 (Detail as per GR, Unless UNTILL Specified)  
 HOT DIP GAVANISED as per IS.2629

	Description	Material	Ref Spec	Qty
1	Link	Mild Steel	IS:2062	

Supply of necessary Pole accessories along with splicing joint enclosures

**Protective Helix (S):**

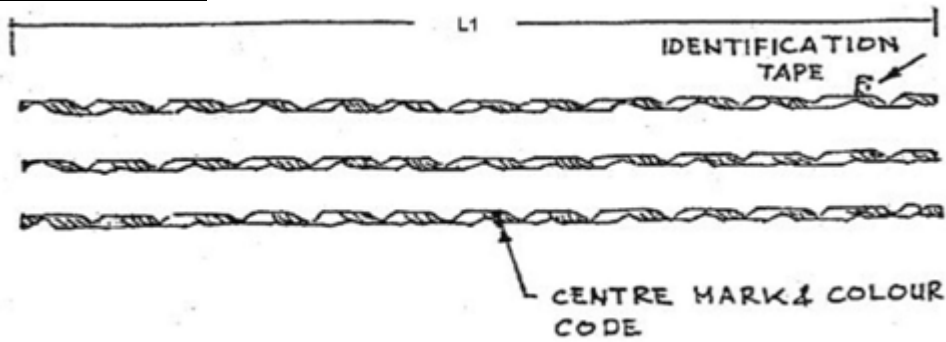

For Example

Dimensions (For Cable Size, D – 14.4 MM)

- i. DIA OF EACH WIRE –  $3.2 \pm 0.1$
- ii. NO OF SETS – 3
- iii. NO OF WIRE PER SET – 5
- iv. LENGTH OF HELIX – 1400

Dimension details for other cable size shall be indicated by the Manufacturer including the pitch of HELIX.

Note: Ends of RODS shall be deburred Tolerance shall be as per IS:2102  
(Detail as per GR, Unless UNTILL Specified)

	Description	Material	Ref Spec	Qty
1	Protective Helx	Aluminium Alloy 6061		

**Armour Grip Suspension Set:**

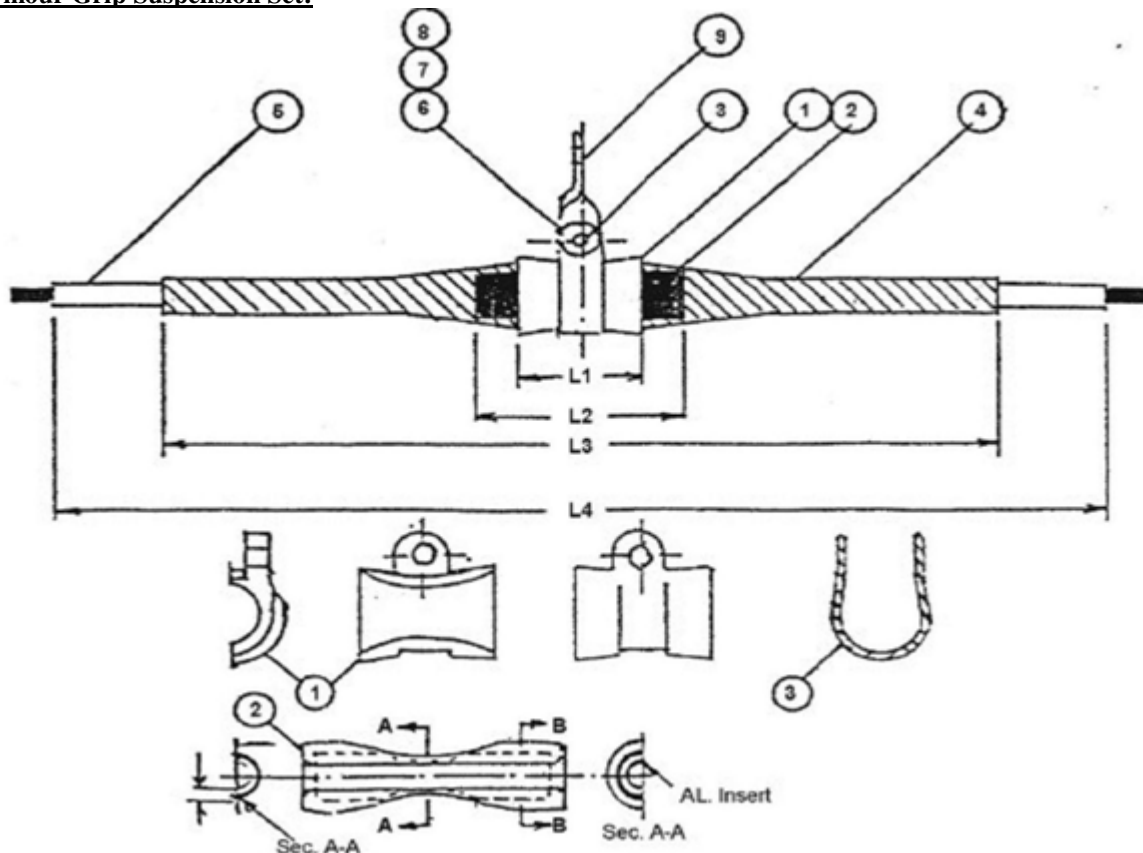

For Example

Dimensions:- Cable Size – 14.4 MM DIA

Cable DIA	L1	L2	L3	L4	Colour	DIA AGS



Supply of necessary Pole accessories along with splicing joint enclosures

					Code	ROD
14.4	115	200	800	1400	Brown	4.25±0.1

Note: Dimensions for different Cable Sizes to be decided after TEST Approval insert Dimensions in MM

Inner DIA	AT – A- A – 22	AT – B-B -22
Outer DIA	33	60

	Description	Material	Ref Spec	Qty
1	Clamp	Aluminium Alloy GDC	IS:617	
2	Inserts) Suspen Clipper	Polychloroprene Compounded		
3	Strap	Aluminium Alloy	IS:617	
4	AGS Helix	Aluminium Alloy6061		
5	Protective Helix	Aluminium Alloy6061		
6	Rivet M16	Mild Steel Galvanised	IS:2062	
7	Flat Washer	Mild Steel Galvanised	IS:2016	
8	Split Pin	Stainless Steel	IS:2549	
9	Twisted Eye	Mild Steel Galvanised	IS:2062	

**Spiral Vibration Damper:**

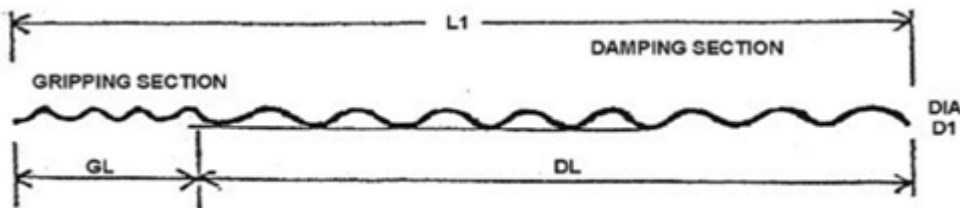

Dimensions in MM:

L1	GL	DL	D1
1346	446	900	12±1

Note: - Tolerance shall be as per IS:2102  
(Detail as per GR, Unless UNTILL Specified)

	Description	Material	Ref Spec	Qty
--	-------------	----------	----------	-----

Supply of necessary Pole accessories along with splicing joint enclosures

1	Spiral Vibration Damper	Polyvinyl Cokpounded		
---	-------------------------	----------------------	--	--

**Demountable Pulley :**

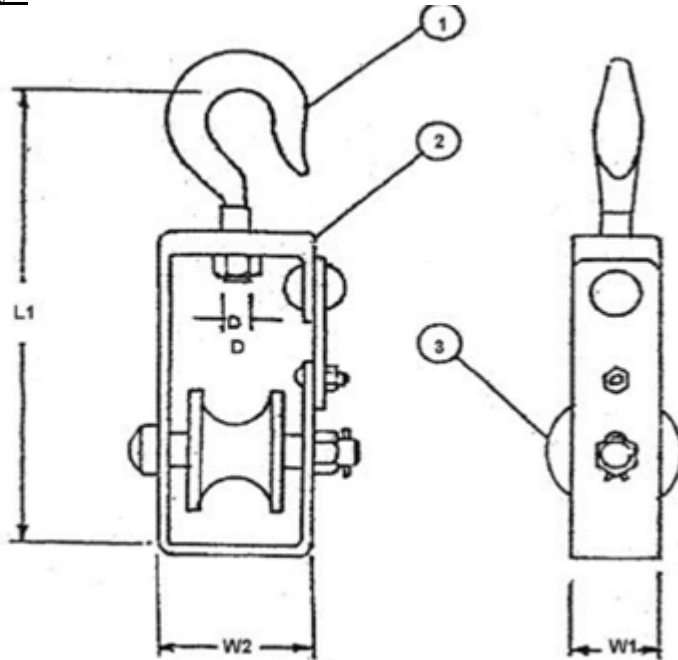

Dimensions in MM:

L1	W1	W2	D
280	50	92	12

Note: - Tolerance shall be as per IS:2102  
 (Detail as per GR, Unless UNTILL Specified)  
 FEROUS PARTS ARE HOT DIP GAVANISED as per IS.2629

	Description	Material	Ref Spec	Qty
1	HOOK	Galvanised Steel		
2	BODY	Galvanised Steel		
3	SPOOL	Aluminium Coated Neoprene		

DEMOUNTABLE PULLY	
NOT TO SCALE	Unit-MM

### **A.3 Supply of Joint Enclosure & Splicing**

#### **Features**

- Standard fiber count 24 to 48 F
- Universal type i.e. suitable for all type of cable (ADSS OFC, Armoured and metal free cable)
- Provide scope for straight / branch joints
- Resistant to chemicals and corrosive atmosphere.
- Easy re-entry and closing with mechanical plastic clamp.
- Shall be water and air proof.
- Ribs on the body for extra strength
- 6 Cable entry port & 1 oval port
- Suitable for cable size upto-30mm
- Mounting Bracket for erecting on pole vertically straight.
- Dome type

#### **Dimensions**

- Length-395mm  $\pm 5\%$
- Outer diameter-273mm  $\pm 5\%$

